

INSTALLATION AND PROGRAMMING GUIDE

9651

HARDWIRED CONTROL UNIT

EAT•N

Powering Business Worldwide

9651 Hardwired Control Unit Installation Guide

This document applies to control panels using software version 5.00.17 or later.

© Eaton's Security Business 2015.

Part number 12593879

Issue 2.0, 8th September 2015

Every effort has been made to ensure that the contents of this book are correct. However, neither the authors nor Eaton's Security Business accept any liability for loss or damage caused or alleged to be caused directly or indirectly by this book. The contents of this book are subject to change without notice.

Printed and published in the UK.

Contents

1. INTRODUCTION	1
About this Manual	1
Features of the Control Unit	2
Elements of the IAS	3
9941 and 9943 Keypads	4
User Control	4
2. TECHNICAL DESCRIPTION	7
Control Unit Specification	7
General.....	7
Power Supply	7
Outputs	8
Inputs.....	8
Fuses.....	8
Compatible Equipment.....	9
Control Unit PCB Layout.....	10
3. INSTALLATION	11
Overview.....	11
Cabling for Keypads.....	12
Fitting the System	13
Fitting the Control Unit Case	13
Fitting a 9941 or 9943 Keypad	13
Wiring the Control Unit.....	14
Cable Entries.....	14
Mains Connection	14
Keypads.....	15
Connecting Sounders	16
Connecting Detector Circuits to the Main PCB	18
Programming Outputs.....	20
Wiring Keyswitches.....	20
Communicator	21
Fitting a Battery.....	23
Initial Start Up	24
4. PROGRAMMING	25
Introduction	25
Operating Modes	25
Entering Installer Mode	26
Using Programming and Testing Commands	26
Leaving Installer Mode.....	27
Restoring Default Access Codes (first stage reset).....	27
Performing an Engineer Reset.....	28
Restoring Default Command Settings.....	28
Adding and Deleting Tags.....	28
Programming Commands.....	30
Testing Commands.....	63
90: Reading the Event Log	63
91 to 96: Testing Outputs.....	66
97: Engineer Walk Test	66
199: Display Zone Circuit Resistance	67
991: Show Software Version.....	67
System Configuration.....	68
PD 6662 / prEN 50131-1: 2004 Compliance.....	68
Programming Commands Quick Reference	69
Index	75

List of Figures

Figure 1. Elements of an Intruder Alarm System.....	3
Figure 2. 9941 and 9943 Keypads.....	4
Figure 3. Control Unit PCB Layout.....	10
Figure 4. Backplate of the 9940 Keypad.....	13
Figure 5. Mains Connection.....	14
Figure 6. Keypad Connections.....	15
Figure 7. 9941/9943 Panic Attack Connections.....	15
Figure 8. Keypad Addressing.....	16
Figure 9. Sounder Connections.....	16
Figure 10. CCL Connections (common tamper).....	18
Figure 11. FSL Connections.....	19
Figure 12. Colour Code for FSL Resistors.....	19
Figure 13. Wiring Examples for Open Collector Outputs.....	20
Figure 14. Connecting a Keyswitch.....	21
Figure 15. Plug-By Communicator Wiring.....	21
Figure 16. Fitting a Plug-by Communicator.....	22
Figure 17. Fitting Control Unit PCB.....	23
Figure 18. Fitting a Battery.....	23

1. INTRODUCTION

About this Manual

This manual is divided into four chapters:

1. Introduction: this describes the parts of an Intruder Alarm System (IAS) based on the 9651 control unit.
2. Technical Description: this defines the operating parameters of the different parts of the system.
3. Installation: this explains the tasks involved in installing an IAS using the 9651 control unit.
4. Programming: this explains how to enter and exit programming, and lists the commands available to the installer.

The control unit is designed to be fully programmable to suit individual user and site requirements. Installers can program units from the keypad, entering instructions using the three-digit commands described in Programming.

Features of the Control Unit

The control unit provides:

- On-board connections for 8 Fully Supervised Loop (FSL) zones or 8 Closed Circuit Loop (CCL) zones with a common tamper.
- Connections for 3 fully programmable panel outputs.
- A 4-wire bus for keypads.
- Internal sounder loudspeaker output with Chime, Alarm, Fire and Entry/Exit tones (the volume of the Entry/Exit and Chime tones can be adjusted).
- 8 programmable plug-by outputs (for connecting a standalone communication device).
- Fully programmable operation for zones and levels.
- Installer-programmable Engineer Code.
- Support for up to 50 separate users.

User facilities include:

- 4 different security levels, which can be programmed by the Installer as a full set and 3 part sets.
- Proximity tag reader for setting and unsetting the system with 9943 keypad.
- Dual key alarms from the keypads (Panic Alarm, Medical and Fire).
- Remote Panic Alarm input to 9941/9943 keypad (software version 5.00.11 onwards).
- User-programmable Duress Code.

Test facilities include:

- 700-entry event log.
- Output test commands.
- Engineer walk test command.

Elements of the IAS

An IAS comprises a control unit in a shielded case, with 1 to 4 separate keypads and various detectors or other devices, for example keyswitches, connected to programmable zones.

The control unit has eight zone connectors on its printed circuit board (PCB).

Figure 1 shows how these elements are connected. In this example, the control unit (1) is directly connected to 6 detectors (3) and 2 door contacts (4). There are 4 keypads (2) on the bus.

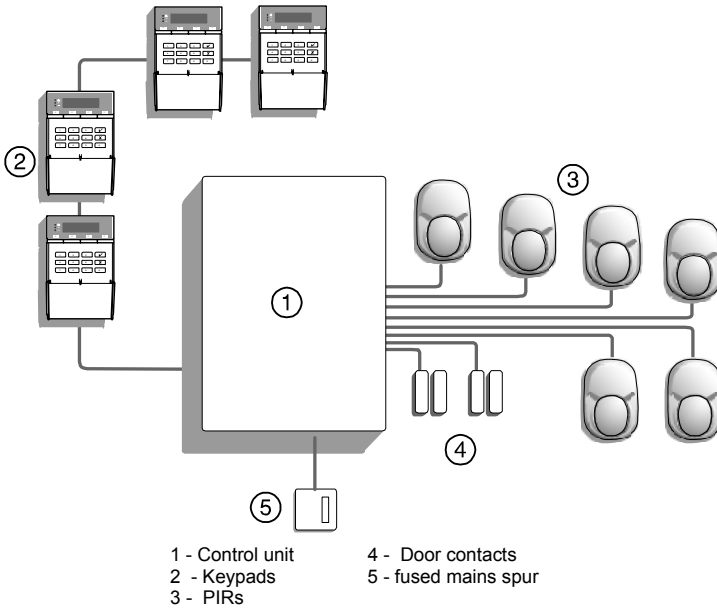

Figure 1. Elements of an Intruder Alarm System

9941 and 9943 Keypads

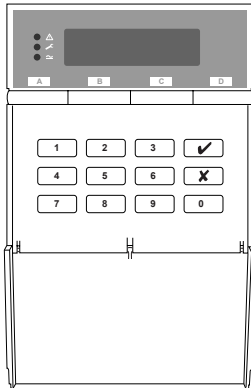

Figure 2. 9941 and 9943 Keypads

The control unit supports the connection of 9941 and 9943 keypads. The 9943 has a built-in wide-area proximity reader and connections for an external panic alarm switch. Both have a two-line 16-character Liquid Crystal Display (LCD) that can display alarm information, programming settings and other information. There are three LEDs that have the following functions.

- △ Alert lamp – Flashes to highlight unacknowledged alert, glows for acknowledged conditions, and goes out when all conditions have been rectified.
- ⚡ Service lamp – Glows if the system needs an installer reset.
- ≈ Mains lamp – Glows when using mains power. Flashes when using the stand-by battery.

Note: Depending on how the system is set up, the LEDs may not operate until a user code is presented.

User Control

The control unit provides 50 independent User access codes and a separate Duress Code. Users can change these codes at any time but cannot use them to program the system. During installation, the Installer can select whether access codes use four or six digits.

Users can set only one level at a time. Level A sets the whole system. Levels B, C and D set parts of the system. The Installer allocates zones to levels, but all keypads operate the entire system. There is only one sounder output for the whole system, and you can use a loud-speaker for setting tones and local alarms. All users belong to the whole system.

(This page is intentionally blank.)

2. TECHNICAL DESCRIPTION

Control Unit Specification

General

Environmental	Class 2
Security	EN50131-1 or PD6662 Grade 2x
Operating temperature	-10° to +55°C
Humidity	96% RH
Dimensions	235mm W, 245mm H, 90mm D
Weight	3.3 kg
Internal Clock	±10 minutes over one year (depending on the accuracy of the mains supply frequency).

Suitable for use in a system that is designed to comply with EN50131-1, ACPO-IAS Policy, NSI NACP14.

Power Supply

All currents accurate to ±5%.

Mains power supply 230VAC +10%/-15%, 200mA max, 50/60Hz
±5%

System power supply 13.8VDC, 1.0A

Battery charge current limit 250mA

To comply with the requirements of EN50131, the total current taken from the power supply, not including the battery recharge current, but including auxiliary outputs and other devices, must not exceed 750mA.

Nominal power requirements (DC):

9651 130mA quiescent, 220mA active

9941 20mA quiescent, 60mA backlight on

9943 30mA quiescent, 70mA backlight on

Standby battery (not supplied) 12V rechargeable lead-acid, gel-type battery.

Low battery voltage cutoff = 10V.

Recommended manufacturers: Yuassa, Yucel or Fiamm.

Note: Grade 1 and 2 compliance requires the panel to continue for a minimum period of 12 hours on a standby battery. To calculate the minimum capacity battery to achieve this requirement, determine the total current taken by external devices and the panel and multiply by 12.

Cooper Security Ltd recommend that you fit at least a 7Ah battery.

Outputs

OP 1, 2, 3	Open-collector transistor outputs, 500mA, 12VDC, negative applied.
LS	Supports two parallel-connected, externally mounted loudspeakers for internal sounder or EE tones: minimum speaker impedance 8Ω.
AUX	500mA, 12VDC minimum, 13.8VDC maximum, ripple ±2% maximum.
Communications outputs	12V logic outputs, negative applied in alarm (positive removed), 50mA maximum.

Inputs

TR	Tamper return for Bell
Tellback/Remote reset**	+12V applied to operate reset.
Line Fault input**	+12V applied to indicate line failure.

** *These inputs appear as pins on the connector for the plug-by communicator. See page 21.*

Fuses

The panel uses fast-acting polyswitch fuses for overcurrent protection:

- F1 – 12V AUX output
- F2 – Battery output
- F3 – Bus 1

Note: Polyswitch fuses automatically reset when the load is entirely removed.

The panel uses a T-250mA mains fuse.

Compatible Equipment

Proxtagpk5	Pack of five proximity tags
9941EN	9941 LCD Keypad
9943EN	9943 LCD Keypad with built-in Proximity Reader
660xx-00	Wire-in speech communicator
SD1-UK	Speech Dialler
TSD2-xx	Speech and text dialler
SD3	GSM speech and text dialler
8400UK-21	Wire-in 8-channel digital communicator
XCELW	Wired PIR detector (12m range)
XCELWPT	Wired PIR detector (pet tolerant)

Control Unit PCB Layout

Figure 3 shows the layout of the PCB used in the control unit.

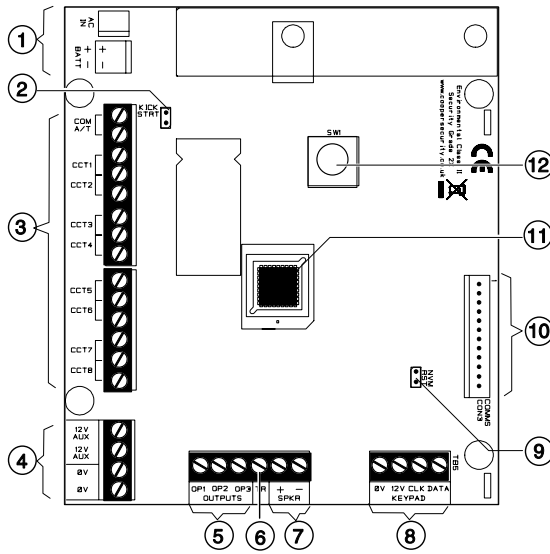

- | | |
|--|---|
| 1. Power input: 12vdc battery and 21vac from transformer (pre-wired) | 7. Speaker connector |
| 2. Kick Start pins | 8. Keypad connector |
| 3. Zone connectors | 9. NVM Reset pins |
| 4. AUX power | 10. Plug-by (standalone) communicator connector |
| 5. Outputs (3 open collector outputs) | 11. Processor in socket |
| 6. Tamper return from external sounder | 12. Lid tamper switch |

Figure 3. Control Unit PCB Layout

3. INSTALLATION

Caution: Always remove mains power before opening the case lid. Do not work inside the control unit with mains power present.

Overview

A typical installation comprises the following main steps:

1. Survey the site and decide on positions for wired detectors, control unit, keypads, external and internal sounders. As part of the survey ask the users what facilities they need.
2. Ensure that there is a suitable mains supply present at the site of the control unit.
3. If you are going to use a communicator, arrange for a PTT (Public Telephone and Telegraph) connection point near to the control unit.
4. Install the wired detectors and run cables to the site of the control unit. Connect each detector to its cable.
5. Run cables from the sites of the keypads, external and internal sounders to the site of the control unit.
6. Install keypads and connect them to their cabling. Ensure that each one has the correct address setting.
7. Install internal and external sounders and connect them to their cabling.
8. Install the control unit and connect it to the mains supply cabling. Do not apply power at this point.
9. At the control unit, complete all connections to detectors, keypads and sounders.
10. Apply power and program the control unit.
11. Test that the intruder alarm system operates as required.
12. If required, install a communicator, connect it to the PTT network and check that it operates correctly.
13. Hand the system over to the users and instruct them in its use.

Cabling for Keypads

Cooper Security recommends that you use 8-core 7/0.2 or 16/0.2 alarm cable for wiring keypads. You can connect the keypads in either a star or bus configuration. If you intend to use long cable runs, Cooper Security recommends that you use star wiring with no more than 200m of cable per branch.

The maximum length of any one run from the control unit to the most remote keypad depends on the number of items connected to the cable. You can double the maximum length for 7/0.2 cable by using two cores each for the 0V and 12V terminals or by using 16/0.2 cable. The table below shows the maximum recommended cable lengths in metres for 7/0.2 cable, assuming that you connect all keypads at the end of a single cable run. You may be able to improve on these figures by spreading keypads along the cable length.

8-core 7/0.2 cable

Number of kpds	1 core	2 cores on 0V and 12V
One	200	–
Two	100	200
Three	65	130
Four	50	100

It is possible to extend the keypad cable run by using additional power supplies, but only up to the recommended maximum of 200m.

When carrying out the cabling, there are two important points to remember:

1. Do not connect anything other than keypads to the bus. The keypad bus power supply is limited to a maximum of 400mA.
2. Check between 0V and 12V on the keypad bus at the point furthest from the control unit: the voltage must be at least 12.0VDC when all the keypad backlights are on.

Note: The following instructions assume that you have already run all the necessary cabling.

Fitting the System

Fitting the Control Unit Case

1. Remove the control unit case from its packaging.
2. Remove the front screws and slide off the case lid.
3. The upper part of the case back has a central keyway. Mark and drill a hole for the keyway. Temporarily fix the case back to the wall. Mark the position of two more fixing holes, remove the case back and drill the holes.
4. Refit the case back to the wall using screws no less than 30mm x No 8, with dome or pan heads.

Fitting a 9941 or 9943 Keypad

Note: If you are fitting more than one 9943 keypad to a control unit then make sure that there is at least 1m distance between individual 9943 keypads. Beware of mounting 9943's back to back on opposite sides of a wall. When 9943 keypads are closer than 1m to each their prox tag readers interfere, and neither keypad can read prox tags.

Figure 4 shows the backplate and the position of mounting holes.

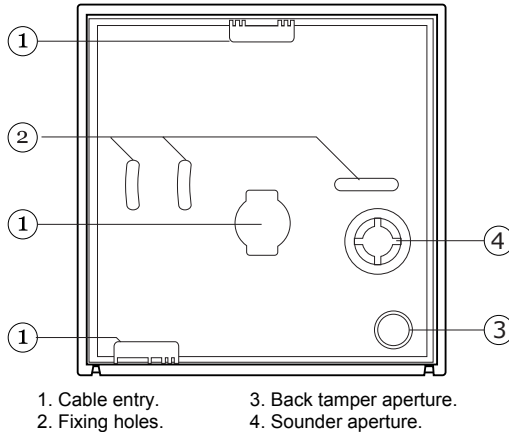

Figure 4. Backplate of the 9940 Keypad

Use No 8 or 6 screws (M4/M3.5) to mount the keypad.

When mounting the front of the keypad (containing the keypad pcb) onto the backplate make sure that the tamper switch operates.

Wiring the Control Unit

Cable Entries

The control unit case back provides several cable entries. It is designed to stand away from the wall to leave space for the cables.

Mains Connection

Connect the control unit to a suitable supply using a double pole disconnect device in accordance with EN60950-1:2001 Clause 3.4.3. Connect the supply to the control unit using the 3-way terminal block located on the case back. Secure the cable to the case anchor point using the cable tie provided.

Notes:

1. The control unit has a T-250mA internal mains fuse.
2. All electrical connections should be carried out by a qualified electrician.

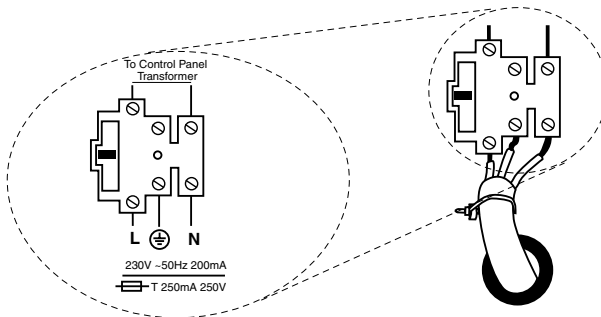

Figure 5. Mains Connection

Connect the 21VAC lead from the mains transformer to the main PCB. See Figure 3 for the location of the 21VAC connector.

Caution: Do not apply mains power at this point. Do not work inside the control unit case when mains power is present.

Keypads

Connecting Keypads

Figure 6 shows the connections for keypads. Use the "ET" connector terminals on the keypad PCB to connect an exit terminate button or lock switch. If you are using a lock switch, do not connect any other devices to these terminals.

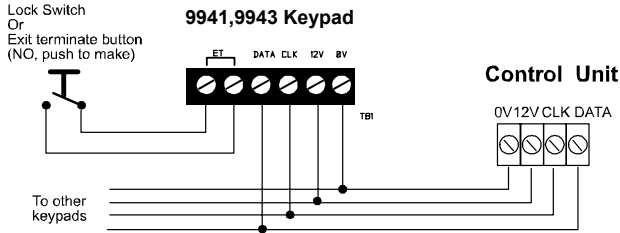

Figure 6. Keypad Connections

The 9941 and 9943 keypads can be connected to an external panic attack button, as shown in Figure 7. If the panic attack does not contain a tamper switch, link the pair of "EXT TAMPER" terminals. Separately link both pairs of terminals if no panic button is used.

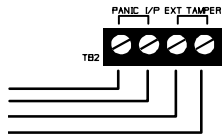

Figure 7. 9941/9943 Panic Attack Connections

Notes:

1. *Wired PA switches connected to the keypad work only with software version 5.00.11 onwards.*
2. *Wired PA switches connected to keypads do not work with the older versions of 9651 pcb.*

Keypad Addressing

The control unit is supplied with one keypad. If you have fitted more keypads, each one must be given a separate "address". Links LK2 to LK4 set the keypad address, as shown in Figure 8.

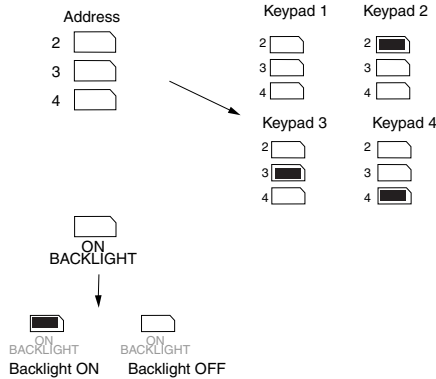

Figure 8. Keypad Addressing

Backlight

When supplied from the factory, the control unit is configured with the backlight On. To turn the backlight Off, remove the jumper from the "ON BACKLIGHT" link, shown in Figure 8.

Connecting Sounders

Figure 9 and the following tables show the wiring required to connect the external sounder (bell box) and optional internal sounders.

Note: If a 2k2 resistor is fitted at the tamper return (TR) terminal at the bell box, use Command 59 to select this EOL mode of termination.

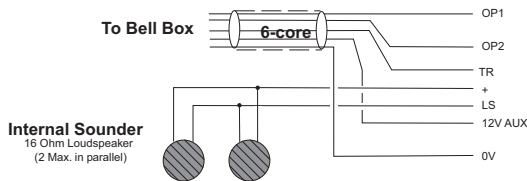

Figure 9. Sounder Connections

Lyntech Ltd - 120 LED/120 Iexon

Control Panel Terminals	OP1	OP2	TR	12V AUX	0V
Bell-Box Terminals	TRG	STRB		HOLD +	

Elmdene Rapier 300, 4000, 5000, 6000; Prima 100-600; Starlight 020

Control Panel Terminals	OP1	OP2	TR	12V AUX	0V
Bell-Box Terminals	-R	-ST	RTN	+H	-H

CQR Security - Sigma, Cequera, Plus and Ultima

Control Panel Terminals	OP1	OP2	TR	12V AUX	0V
Bell-Box Terminals	SIREN TRIG	STROBE TRG	A/T RET SIG	HOLD OFF +VE	HOLD OFF -VE

Ventcroft Security - Vision, Classic and Spirit

Control Panel Terminals	OP1	OP2	TR	12V AUX	0V
Bell-Box Terminals	TRIG -	STB -	RTN	HOLD OFF +VE, STB +VE	HOLD OFF -VE

Flashguard - Xtra

Control Panel Terminals	OP1	OP2	TR	12V AUX	0V
Bell-Box Terminals	TRIGGER	STROB-	SUPPLY -	SUPPLY + STROBE +	TAMP OUT

Intellisense - AG3

Control Panel Terminals	OP1	OP2	TR	12V AUX	0V
Bell-Box Terminals	S-	ST-	TR	V+	V-

Connecting Detector Circuits to the Main PCB

The connectors for the detector circuits, or zones, are on the left-hand edge of the main PCB in the control unit. The table below summarises the number and type of zones that can connect to the main PCB of the control unit. Use Command 21 to specify which of these wiring types you are using. You cannot specify different wiring types for different zones.

Control Unit Zones	Wiring Type
8	four-wire CCL (c losed c ircuit l oop) with common tamper
8	two-wire FSL (f ully s upervised l oop)

CCL Connections

Figure 10 shows how to connect four-wire CCL zones. Note that there is a single Global tamper loop that serves all zones.

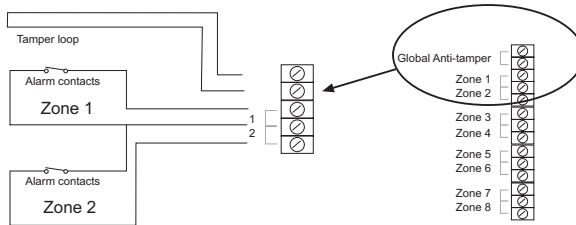

Figure 10. CCL Connections (common tamper)

FSL Connections

Each FSL zone is a "Fully Supervised Loop" using a two-wire closed loop. As shown in Figure 11, the loop uses resistors of different values to differentiate between "Circuit" and "Tamper" signals: a 2K2 resistor fitted in series at the end of the wired loop (EOL) and a 4K7 resistor fitted across the alarm contact. With the loop in a normal state and the alarm contacts closed (shorting out the 4K7 resistor), the total resistance of the loop is 2K2. When the alarm contacts open (removing the short from the 4K7 resistor), the resistance of the loop increases to 6K9 and so the control unit detects an alarm condition. If a tamper device opens, the loop resistance becomes infinite (open circuit) and so the control unit detects a tamper signal.

To connect a detector to an FSL loop, you must wire suitable high-tolerance resistors to the detector. Always check resistor colour coding and tolerance before wiring resistors into circuit (see Figure 12).

The wiring resistance of the cable to the detector (including joints) should not exceed 100 ohms. The recommended maximum cable length within a zone is 200–300m.

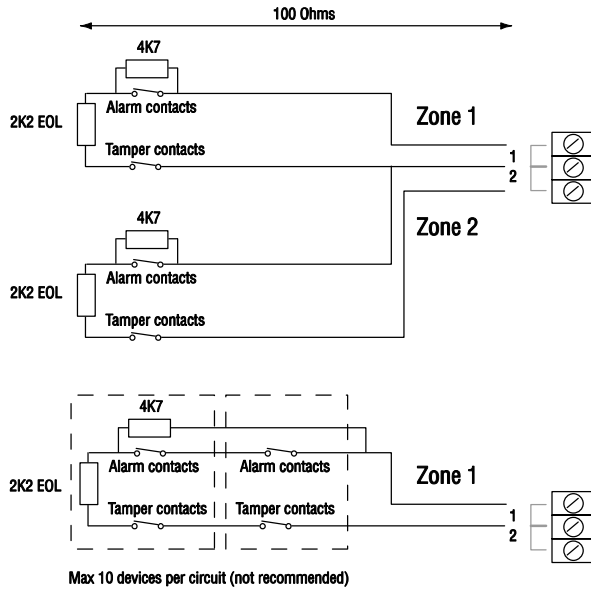

Figure 11. FSL Connections

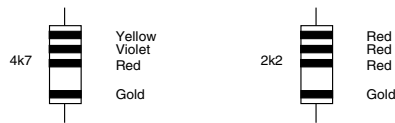

Figure 12. Colour Code for FSL Resistors

Programming Outputs

Control unit panel outputs can be programmed using the commands shown in the table below. Open collector outputs are of a "pull down" type that provides negative-applied control signals; the system adjusts the output polarity when you select the output type.

Output	Type	Command
OP1	open collector	81
OP2	open collector	82
OP3	open collector	83

Figure 13 shows some examples of applications for open collector outputs (OP3 is used in these examples).

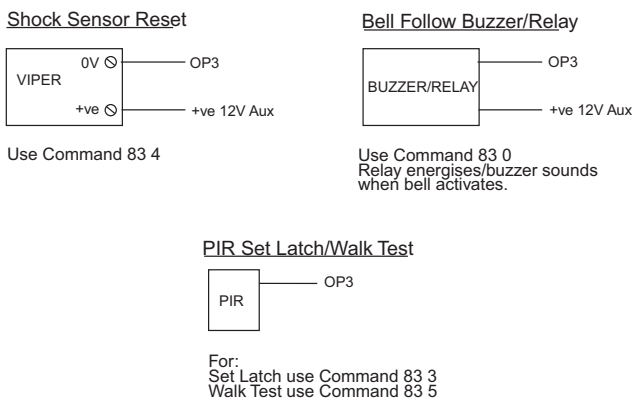

Figure 13. Wiring Examples for Open Collector Outputs

Wiring Keyswitches

To allow a user to set and unset the system using a keyswitch, connect a fixed position or spring loaded (momentary) key switch to a zone input. When programming the control unit select zone type (KM) for momentary or (KF) for fixed position keyswitches. See Command 185 for keyswitch auto-reset.

Figure 14 shows the connections for a keyswitch.

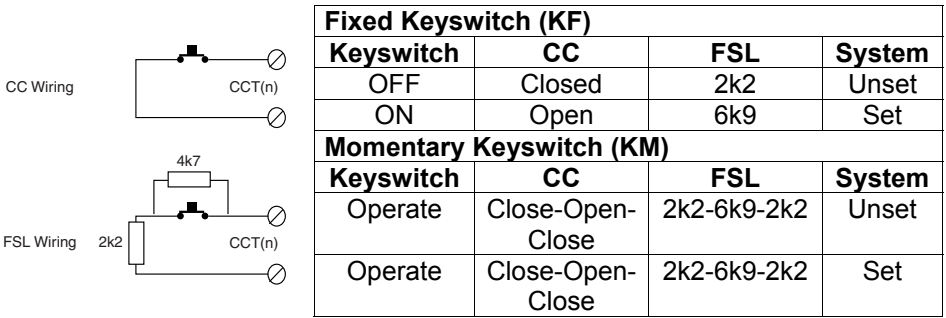

Figure 14. Connecting a Keyswitch

Note:

If you connect a keyswitch as a zone it can be used to set and unset the level to which the zone is assigned.

Communicator

The 9651 can be fitted with a communicator or speech dialler, for example the Scantronic 660, 8400, and 8440 digital communicators or the SD1, SD2 or SD3 Speech diallers. To connect an SD1, SD2 or SD3 follow the instructions provided with those products. Figure 15 shows the connections for the communications wiring harness.

Com Connector Cable, Part No. 485210

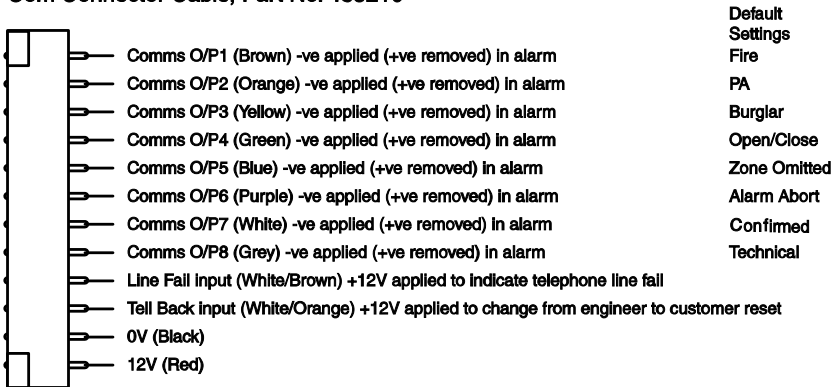

Figure 15. Plug-By Communicator Wiring

Note: Comms O/P4 will be active when the system is unset. This is normal, as a system being unset is equivalent to an alarm signal.

To fit a communicator, follow the instructions below.

Caution: Follow the instructions in the order shown, or you may damage the control unit and/or communicator.

1. Disconnect mains and battery power from the control unit and remove the case lid, if the system has already been installed.
2. Detach the main PCB from the support pillars in the control unit case, and lift the PCB carefully to the left. Fit the communicator between the PCB support pillars, making sure that the main PCB can fit back into position (see Figure 16).

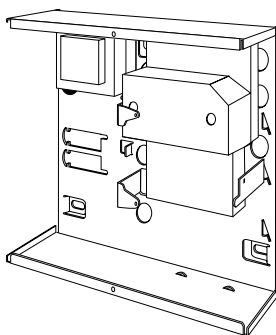

Figure 16. Fitting a Plug-by Communicator

3. Make any necessary connections from the communicator to the communication wiring harness. The default is a positive voltage when the output is inactive but this can be inverted if required using Command 159.
4. Plug the Communication Wiring Harness onto the communications connector on the main PCB.
5. Re-fit the PCB to the support pillars. Secure the PCB to the support pillars with the screws provided (Figure 17). Make sure that the bottom left corner of the PCB is seated on its support pillar.

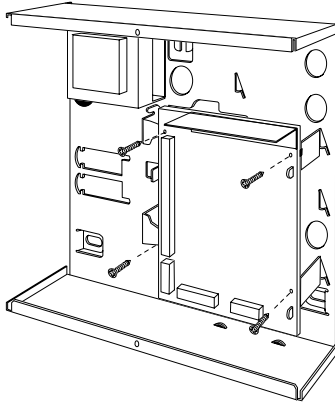

Figure 17. Fitting Control Unit PCB

If the system has already been installed:

- 6. Re-connect the battery.
- 7. Fit the case lid.
- 8. Apply mains power.
- 9. Test communicator operation.

Fitting a Battery

Fit a rechargeable battery into the back of the case. There is space in the case for a 12V 7Ah battery; make sure the battery terminals are oriented in the position shown in Figure 18. Cooper Security recommend that you fit a 7Ah battery.

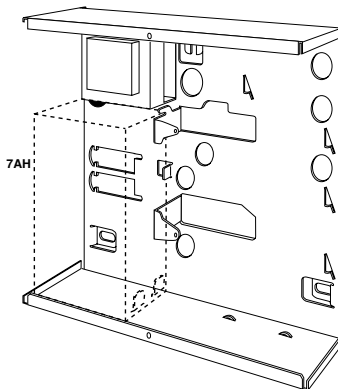

Figure 18. Fitting a Battery

Initial Start Up

Before applying power to the control unit, ensure that:

- All keypads have been addressed and connected.
- All external and internal sounders are connected.
- All wired zone circuits are connected.

Then:

1. Connect the battery to the control unit PCB.
2. Briefly short the Kick Start pins together (see Figure 3).
The internal sounder may sound. Ignore any display at this stage.
3. Key in the factory default User access code: 1234.
The internal sounder stops. Ignore any display or lamps.
4. Fit the case lid before applying mains power (this covers the live wiring and closes the tamper switch).
5. Apply mains power.
6. Key in 0 followed by the factory default Engineer Code: 7890.

Note: You do not have to remove the case lid.

The display shows:

Installer Mode

You are now in installer (programming) mode.

The Programming Guide explains how to program the system.

4. PROGRAMMING

Introduction

This chapter is divided into four sections:

1. **Introduction** provides an overview of how to program a 9651 control unit.
2. **Programming Commands** lists and describes the commands available to program aspects of a 9651 control unit's operation.
3. **Testing Commands** lists and describes the commands available to test a newly installed alarm system based on a 9651 control unit.
4. **System Configurations** describes how to set up a 9651 control unit so that it complies with industry standards.

The 9651 control unit is fully programmable to accommodate individual user and site requirements. Installers program units from the keypad. Enter instructions using the two and three-digit commands described in "Programming Commands". Before you start, familiarise yourself with the control unit's functions and the programmable options described in this manual.

For guidance on using 9651 control units, refer to the *9651 User Guide*.

Operating Modes

The alarm system has three basic modes of operation that provide access to commands appropriate to different types of users:

1. **User mode** allows setting, unsetting and resetting of the system, along with some basic commands. There may be many user codes of this type.
2. **Master user mode** provides access to all user commands, including those available in user mode. The master user can configure other users. There is only one user code of this type.
3. **Installer mode** provides access to the installer menu, which contains the programming and testing commands described in this Guide. There is only one user code of this type.

To enter either of the user modes, enter a user code (which may be four or six digits) or present a proximity tag. To select a user command, enter the command number.

To enter installer mode, enter zero followed by the installer code (which may be four or six digits). To select an installer command, enter the command number.

In addition to the three standard operating modes, there is a special **Duress mode** which provides the same access as user mode but also secretly communicates the duress status. There is only one user code of this type. See Command 49 for details on how to enable Duress Code, and Commands 151-158 for details on how control the plug-by communicator outputs.

Entering Installer Mode

Chapter 3 describes how to enter installer mode for the first time in a new installation. You can use this mode at any time, provided that the system is unset and not in alarm. To enter installer mode:

1. Make sure the system is unset.

Note: If you have selected defaults for Finland, Norway, Sweden or Denmark (Command 0), or a user has selected user command 3, you must enter a valid user code at this point.

2. Key in the Engineer Code (default 7890).

Notes:

1. With software versions earlier than 5.xx.xx key in 0 followed by the default Engineer Code 7890.
2. You do not have to remove the case lid.

The display shows:

Installer Mode

You are now in installer mode.

While the system is in installer mode, all keypads except the one that you are using will be locked and will display "Busy".

Using Programming and Testing Commands

When delivered from the factory, the control unit already has default settings. To change the default settings:

1. Enter installer mode.
2. Key in the appropriate command number and press ✓.
The display shows the current value of the command.
3. Key in digits to select the value you require.
The display shows the new value.
4. Press ✓ to store the new value of the command.

Note: If at any time you change your mind, repeat steps 1 to 3. The 9651 Quick Reference Programming Guide shows the commands and their values. "Y" to the right of a value shows that it is the factory default.

Leaving Installer Mode

When you have finished programming the control unit:

1. Press 99✓ at the keypad

The display shows (for version 5 software):

99:Checking bus

Followed by:

99:Exit Eng ?

2. Press ✓.

The display shows:

99:Checking Sys

followed by the user mode display (either time and date or unset state).

The system is now in user mode.

Note: If any 24-hour, Fire, PA or Technical zones are active when you enter Command 99, the keypad gives an error tone and displays the faults. Correct the problems identified. When the display shows "No Faults", press ✓ to enter user mode.

Restoring Default Access Codes (first stage reset)

The default (original) access codes are:

	4-digit	6-digit
Engineer Code	7890	567890
Access Code User 1	1234	123456
Access Code Users 2 to 50	✕002 ... ✕050	✕00002 ... ✕00050
Duress Code	✕051	✕00051

Note: To activate the Access Codes (02 to 50) and Duress Code, which are initially inactive, User 1 must change the defaults to the correct codes. The 9651 User Guide explains how to do this.

To restore all access codes to their default settings:

1. Remove mains power.
2. Open the case and disconnect the battery.
3. Identify the NVM Reset pins and Kick Start pins on the main PCB (refer to Chapter 3).
4. Short circuit the NVM Reset pins with a wire link.
5. Short circuit the Kick Start pins with a wire link.
6. Reconnect the battery.
7. Remove the wire links from the NVM Reset pins and Kick Start pins.
The control unit will load the factory default access codes listed above.
8. Close the control unit.
9. Apply mains power.
10. Carry out an engineer reset (see next section).

Performing an Engineer Reset

To perform an engineer reset:

1. Check that the display is showing the alarm condition.
2. Enter installer mode.
3. Enter 99 ✓✓.

The display returns to the time and date.

Restoring Default Command Settings

To restore all command options to their default (original) settings:

1. Enter installer mode.
2. Press 98✓ at the keypad.

The display shows:

Load Default

3. Press 1✓ at the keypad.

The keypad gives a double "beep" confirmation tone and the control unit loads the default settings, erasing all previous selections.

Adding and Deleting Tags

You can use any industry-standard ISO tag or card with the 9943 keypad. To purchase tags from Cooper Security, quote part number Proxtagpk5.

A tag acts as an alternative to a user access code. You can assign a user a tag, an access code, or both. You cannot assign a tag to the Master User (User 01) or the Installer (User 00). This means you can assign up to 49 tags on a system, one each for Users 2 to 50.

The 9943 keypad has a proximity coil that makes the whole case sensitive to tags.

To Add a Tag

1. Key in User 01 access code while the system is unset.

The display shows:

Select?

2. Press 4 to select the change codes option.

The display shows:

Old Code= _

3. **EITHER**

Enter the access code of the user for whom you want to program a tag and press ✓.

OR

Press ✕ repeatedly until the display shows the user number of the user for whom you wish to program a tag and press ✓.

The display shows the user number and any text description you have programmed for that user.

- 4. Press ✓.

The display shows the user number and an underscore, for example:

User 06 = _ _ _

- 5. Present the proximity tag to the front of the keypad.

The system learns the identity of the tag and links it to that user number. The keypad gives a double "beep" to confirm that the tag has been learned successfully.

The keypad displays the date and time.

- 6. Repeat steps 1 to 5 for other tags, as necessary.

To Delete a Tag

Note: If you delete a tag, you also delete that user's access code.

- 1. Key in User 01 access code while the system is unset.

The display shows:

Select?

- 2. Press 4 to select the change codes option.

The display shows:

Old Code= _

- 3. Enter the User 01 access code again and press ✓.

The display shows "User 01" and any text description for that user.

- 4.

The display shows the user number and any text you have programmed for that user.

- 5. Press ✓.

- 6. Key in "0000" and press ✓.

The system deletes the tag and the user's access code. The keypad gives a double "beep".

Programming Commands

0: Country PTT Defaults

Use this command to select the country and PTT (Public Telegraph and Telephone) defaults; it also loads default access codes and programming options. Use Command 126 to select language without making other changes.

Note: If you select options X4, X5, X6 or X7 (Finland, Norway, Sweden or Denmark), the control unit changes the method of entering installer mode (see "Entering Installer Mode" on page 25).

Option		Option		Option	
0	UK (default)	6	Belgium	X3	OEM 2
1	Italy	7	Germany	X4	Finland
2	Spain	8	Switzerland	X5	Norway
3	Portugal	9	Austria	X6	Denmark
4	Netherlands	X1	Ireland	X7	Sweden
5	France	X2	OEM 1		

01 to 08: Zone Programming

There are eight zones available on the 9651 control unit. Key in "01" to "08" and press ✓. The zone programming commands take at least three further digits: the first two specify the zone's type, while the others specify the zone's attributes.

When you key in the zone number and press ✓, the display shows the zone number and any text associated with it. At this point, you can edit the zone text. When the text is as required, press ✓ to display the zone type and attributes. At this point, you can edit them. When they are as required, press ✓ once more to store the changes.

Zone Names

When you key in the zone number and press ✓, the display shows the current zone name with a flashing cursor under the first letter. Zone names can contain up to 12 characters, including spaces and punctuation marks.

Enter letters from the keypad one at a time by repeatedly pressing a number key until the display shows the letter you want. If you make a mistake, press C or D to move the cursor to the letter you want to change and key in the new letter. To delete a name completely, press D to move the cursor onto the first character of the name and then press D again to clear the old name.

When you have finished entering the name, press ✓.

The following table shows the letters generated by each key on the keypad.

1		7	P Q R S
2	A B C Æ Å Ä	8	T U V
3	D E F	9	W X Y Z
4	G H I	0	Space ' () : . - ! &
5	J K L	C	Move right
6	M N O Ø Ö	D	Move left

Zone Types

The following table shows the values available for zone type.

Value	Type	Description
00	Not Used (NU)	Identifies zones that are not used. The system ignores zones of this type. It is not necessary to link the circuit or anti-tamper connections.
01	Panic Alarm (PA)	Operating a device programmed as "Panic Alarm" will start either a silent alarm transmission to the Alarm Receiving Centre (ARC) or an audible alarm, depending on how you have programmed PA Response (see Command 30). PAs operate, whether the system is set or unset.
02	Fire (FR)	Smoke or heat detectors connected to FR type zones cause the speakers to give a distinctive fire signal (internal sounders pulsing "Dee Dah Dee Dah..."). Fire alarms always operate, whether the system is set or unset, and always trigger communications if fitted.
03	Normal Alarm (NA)	A zone programmed as "Normal Alarm" will start an alarm if activated while the system is set.
04	24-hour (24)	This zone causes an internal alarm if violated when the system is unset, and a full alarm if the system is set. If the Installer programs 24-hour zones with "Omit Allow", the user can omit 24-hour zones in Day mode. The control unit reinstates all 24-hour zones if anyone sets the system.
05	Final Exit (FE)	Zones of this type must be the first to be activated on entry. You can use them to set the system using the Final Door Set exit mode. Use Command 39 to set the exit mode for the zone (page 39). Use zone attribute ✖7 to select an entry timer for the zone (page 34) and Commands 201–4 (page 60) to set up the entry timers.
06	Entry Route (ER)	Use this zone type for detectors sited between the Final Exit door/detector and a keypad. If an "Entry Route" zone is violated when the system is set, an alarm will occur. If the Entry/Exit timer is running when an Entry Route zone is violated, no alarm occurs until the Entry/Exit timer expires. Use zone attribute ✖7 to select an entry timer for the zone (page 34) and Commands 201–4 (page 60) to set up the entry timers.
07	Shock Analyser (SA)	You can apply this zone type to zones 1 to 4. The system will not accept this type for zones 5 to 8. Use zone attribute ✖7 to set the sensitivity for the zone (page 34).

Value	Type	Description
08	Technical Alarm (TC)	Use this zone type when you want to monitor equipment, for example a freezer, without raising a full alarm. If a Technical Alarm zone is activated while the system is set, the system makes no audible alarm. However, when a user unsets the system, the keypad indicates a fault. If a Technical Alarm zone is activated while the system is unset, the system starts a pulsed tone from the keypad. If programmed, the control unit also starts communication. When a user enters a valid code, the keypad stops the tone and displays the zone.
09	Keybox (KB)	This zone type is for use in Scandinavia only. When a zone of this type is required, the Installer connects the alarm wires of the zone to a special external key box and the tamper wires to the box enclosure switch. When someone opens the box, the control unit logs the event and communicates it to the Alarm Receiving Centre (ARC). The control unit also provides a Key Box output type, which you can program with Command 151 to trigger one of the plug-by communicator output pins.
10	Smoke Detector (SD)	In Scandinavia only, use this type for zones connected to 12V smoke detectors. This type is active whether the system is set or unset, and the control unit will transmit a specific alarm to the Alarm Receiving Centre (ARC) if triggered. The control unit also provides a Smoke Detector output type, which you can program with Command 151 to trigger one of the plug-by communicator outputs. If a zone of this type causes an alarm, the user will need to enter an access code to disarm and reset the system.
11/12	Keyswitch	<p>There are two Keyswitch zone types: Momentary and Fixed. Use these for zones that connect to an access control keypad, electronic key or other hardwired device used to set or unset the system:</p> <p>11 Momentary Keyswitch (KM) 12 Fixed (or latched) Keyswitch (KF)</p> <p>The keyswitch or similar device can be used to set and unset the level to which the zone is assigned. It cannot be used to reset the system.</p> <p>In a single system, do not assign a Keyswitch zone to levels B, C or D if you have assigned one to Level A (full system).</p>
13	Anti-Mask Zone (AM)	<p>Use this zone type for the anti-mask outputs of detectors with this facility. Connect the detector's alarm and contact wiring to one zone (for example, Zone 07) and its anti-mask outputs to the zone above (for example, Zone 08). Assign the Anti-Mask type to the higher zone; that is, the one connected to the anti-mask outputs (Zone 08 in the example).</p> <p>If an Anti-Mask zone is violated, the control unit starts a Tamper Alarm and shows the message "AM Tamper" on the keypad display. It logs the event to the zone connected to the detector's alarm and contact wiring (Zone 07 in the example). Command 136 defines whether an Anti-Mask zone can be reset by a user or only by the installer.</p>

Value	Type	Description
14	Forbikobler (FB)	This zone type is a Scandinavian type of Entry/Exit zone (the word "forbikobler" means "bypass" in Danish). Use this type for zones connected to standalone external keypads or access controllers. If the zone is triggered by the external keypad during the exit time, the control unit stops the exit time and sets the system. If the zone is triggered while the system is set, the control unit starts the entry time. Use zone attribute X7 to select an entry timer for the zone (page 34) and Commands 201–4 (page 60) to set up the entry timers.
15	AC Fail (AC)	This zone type is triggered by a failure in the AC input to an external power supply. Command 134 defines whether a zone of this type can be reset by a user or only by the installer. Command 137 defines whether the user can override the fault to set the system.
16	Low Battery (LB)	This zone type is triggered by a low voltage in the battery in the external power supply.
17	Battery Fault (BF)	This zone type is triggered by a fault in the battery in the external power supply.
18	Power Output Failure (PF)	This zone type is triggered by a failure in the DC output to the external power supply.
19	Fault (FL)	This zone type triggers a fault condition, causing an alert and preventing the system from being set. The tamper connection operates in the same way as a normal alarm zone (type "NA"). Command 139 defines whether a zone of this type can be reset by a user or only by the installer. Command 140 defines whether the user can override the fault to set the system.

Zone Attributes

The following table shows the values available for zone attribute, depending on the zone type. To set an attribute, key in the appropriate value. To unset the attribute, key in the value again.

Value	Attribute	Valid for	Description
x1	Chime (C)	Normal Alarm (NA) Final Exit (FE) Entry Route (ER) Shock Analyser (SA)	When enabled by the user, the system makes a doorbell-like sound when any zones programmed as "Chime" are opened. This facility operates only while the system is unset. To make the Chime available from keypad sounders but not internal sounders, use Command 22 with option 0.

Value	Attribute	Valid for	Description
✕2	Soak Test (S)	Normal Alarm (NA) Entry Route (ER) 24-hour (24) Shock Analyser (SA)	Use this zone attribute if you want to place on long-term test a detector that you suspect is giving false alarms. Zones with this attribute are disabled for 14 days after you return the control unit to user mode. If the zone is opened while the system is set (or at any time for a 24-hour zone), the control unit logs the event as a "Soak Fail Znn" (nn = zone number) without sounding any bells or starting signalling. The control unit returns the zone to normal use after 14 days, even if the system is set at the time.
✕3	Double Knock (D)	Normal Alarm (NA) Entry Route (ER)	For zones with this attribute, no action is taken on first activation. To cause an alarm, the zone must be activated twice within a five-minute period or remain open for longer than 10 seconds. An alarm will also occur if another double-knock zone is activated within five minutes of the first. Programming a zone as "Double Knock" is a way of reducing false alarms caused by environmental changes but is not normally recommended. Do not apply "Double Knock" to radio zones with a PIR detector. The radio PIR detector uses a lockout timer and will not send a second activation within the Double Knock period.
✕4	Omit Allowed (O)	All	When applied to a zone, this attribute allows the user to omit the zone when setting the alarm. Do not allow the user to omit PA zones. Do not apply this attribute to an FE zone if there is no ER zone present.
✕5	Do Not Use.		
✕7	The meaning of this attribute depends on the zone type:		
	Shock Analyser Sensitivity	Shock Analyser (SA)	You can set this attribute only for a zone of type SA, and only zones 1, 2, 3 and 4 support this type. To set the sensitivity of a shock sensor zone, enter a digit in the range 1 (least sensitive) to 6 (most sensitive). You must enter the whole sequence; for example, to set the sensitivity to 3, press ✕73
	Entry Timer Number	Final Exit (FE) Entry Route (ER) Forbikobler (FB)	To select which of the four entry timers (set up using Commands 201–4, as described on page 60) are used for the zone, enter a digit in the range 1 to 4. You must enter the whole sequence; for example, to select Entry Timer 3, press ✕73

Value	Attribute	Valid for	Description
A	Armed in Level A	All	Always applied. The zone is armed when the user selects Level A.
B	Armed in Level B	All	When applied, the zone is armed when the user selects Level B.
C	Armed in Level C	All	When applied, the zone is armed when the user selects Level C.
D	Armed in Level D	All	When applied, the zone is armed when the user selects Level D.

20: Change Engineer Code

Note: 9651 control units support six-digit access codes as well as the standard four-digit codes. Command 56 sets the code length.

To change the Engineer Code:

1. Make sure you are in installer mode.
2. Press 20✓

The display shows:

20:Code

3. Key in a new Engineer Code.

The display shows:

20:Code xxxx

4. Press ✓
5. Press ✓

21: Zone Configuration

This command enables you to select the wiring type of the zone connectors on the control unit PCB. The default is option 0 for all models.

- 0 Up to 8 closed circuit loop zones (CC + Com A/T).
- 1 Up to 8 fully-supervised loop zones (FSL 2K2/4K7).

22: Loudspeaker Chime

In a single system, a user may find that the Chime tone from the keypads is not loud enough. If so, use this command to make the internal sounder give the Chime tone as well. If you select option 0, the internal sounder emits no tone. Select a value from 1 (quietest) to 9 (loudest) to set the Chime volume (the default is 5). The internal sounder demonstrates the volume when you enter the digit.

23: Remote Reset Enable

Option 1 enables Remote Reset, which is designed to operate with the plug-by communicator. After an alarm, the user keys in an access code to silence the alarm but cannot reset the system. The first alarm message to display and the Service lamp remain visible. The user contacts the Alarm Receiving Centre (ARC), which verifies the user's identity and then sends a signal to the control unit. The Service lamp goes out and the user can then reset the system with any valid access code, provided that there are no faults.

Use option 0 (the default) to disable this function.

Notes:

1. *To ensure option 1 works correctly, you must set System Reset to Engineer (Command 33 option 1) and set a CSID code (Command 50).*
2. *To comply with PD 6662 / prEN 50131-1: 2004, the system must be set to hide status information after 30 seconds (Command 28), in which case the Service lamp will go out after the same period.*

25: Internal Sounder Delay and Duration

Option 0 (the default) makes the internal sounder use the external Bell Delay and Duration times. Option 1 makes the internal sounder continue after the external Bell Delay expires, stopping only when a user enters an access code.

27: Exit Fault External Sounder

This command controls what happens when an exit timer completes and a zone is still violated (for example, when a door is not shut).

Option

- 0 Internal (default). System operates the internal sounders only.
- 1 Local. System operates both internal and external sounders.

Note: Compliance with PD 6662 / prEN 50131-1: 2004 (see page 68) prohibits an alarm after a failure to set the system, which would require Command 27 to be set to option 0. However, if external sounders are preferred, 9x5x control units also provide "Set Fail" outputs that can be used to indicate that an alarm resulted from a set failure.

28: Status Display

If you select option 0 (the default), the keypad displays "Level Set" continuously for the whole time that the alarm system is set. The keypad lamps are illuminated if a relevant condition exists. Select option 1 to clear the display and turn off the lamps 30 seconds after the user's last action.

The following table shows the effect of these settings in more detail.

	Text		Alert lamp		Service/Mains lamps	
Panel Set	0 continuous	1 timed	0 continuous	1 timed	0 continuous	1 timed
No alerts	Level set	Level set 30s, then T&D	Off	Off	On	On* 30s
Alerts	Level set	Level set 30s, then T&D	On	On 30s	On	On* 30s
Panel Unset	0 continuous	1 timed	0 continuous	1 timed	0 continuous	1 timed
No alerts	Level Unset	T&D	Off	Off	On	On* 30s
Alerts	Level Unset	T&D	On	On	On	On* 30s

T&D Time and date * If a relevant condition exists

Note: Compliance with PD 6662 / prEN 50131-1: 2004 (see page 68) at Grades 1, 2 and 3 requires that Command 28 is set to option 1.

29: Entry Alarm Delay Time

This command determines what the system does if a user strays from an Entry Route zone during entry.

If you select option 0 (the default), the system gives an immediate alarm when the user strays from an Entry Route zone during entry.

If you select option 1, the system gives an internal alarm when the user strays from an Entry Route zone during entry but waits for 30 seconds before raising a full alarm. The user can reset the system by entering an access code within that time.

Note: Compliance with PD 6662 / prEN 50131-1: 2004 (see page 68) requires that Command 29 is set to option 1.

30: PA Response

When a Panic Alarm (PA) occurs, the system sends a PA message to the Alarm Receiving Centre (ARC), if a communicator is fitted, and the keypad shows the PA zone when a user disarms the system. With this option, you can choose whether the system also operates the sounders.

Option

- 0 Sounders operate (default).
- 1 Sounders remain quiet.

31: Zone Tamper User/Engineer Reset

Use this command to ensure that the system complies with national requirements for resetting zone tamper indications while the system is unset. If you select option 0 (the default), the user can reset the system after a zone tamper.

If you select option 1, the user can silence the alarm after a zone tamper but an engineer must reset the system by entering the Engineer Code, or by using a remote or anti-code reset (Commands 23 and 50).

Note: See Commands 37 and 38 for reporting and resetting system tampers (for example, attempts to open control unit or keypad cases).

33: System User/Engineer Reset

To require an engineer reset, select option 1. To permit a user reset, select option 0 (the default). Certain types of events always need an engineer reset, irrespective of the option that you choose here:

- Auxiliary 12V supply fuse blown
- Keypad missing or failed
- A low battery at the control unit.

34: PA User/Engineer Reset

To require an engineer to reset the system after a PA, select option 1. To permit a user to reset the system after a PA, select option 0 (the default).

35: First Circuit Lockout

If you select option 0 (Lockout), the first zone to activate during the set cycle is ignored until the system is unset. This is the default.

If you select option 1 (Rearm), the whole system (including the first zone to activate) rearms at the end of the programmed bell run time, provided that the zone is closed. While the zone is open, the system locks it out. If the zone closes after the system rearms, the system reinstates it.

36: Alarm Abort

Users occasionally trigger false alarms by accident. Select option 1 to permit them to abort under these circumstances.

If a user accidentally triggers an alarm while the system is set, the control unit transmits an intruder alarm and starts the Bell Delay and Alarm Abort timers. To abort the alarm, the user must enter a valid access code during the abort period. If the user enters a valid code within this time, the system transmits a restore of the intruder alarm and simultaneously transmits an abort.

Select option 0 (the default) to prevent users from aborting alarms in this way.

Note: The Alarm Abort period is controlled by the Alarm Receiving Centre (ARC).

37: Daytime Tamper Communication

This command defines how the control unit reports tamper indications (for example, an attempt to open a control unit or keypad case) while the alarm system is unset.

Option

- 0 Internal sounder only (default).
- 1 Internal sounder and communication of tamper indication to the Alarm Receiving Centre (ARC).

38: System Tamper User/Engineer Reset

This command defines how to reset the control unit after a tamper alarm (for example, an attempt to open a control unit or keypad case).

To require an engineer reset, select option 1 (the default). To permit a user reset provided that no fault exists, select option 0.

Note: This facility is independent of the options selected in Commands 31 and 33.

39: Level A Exit Mode

Use this command to select the exit mode for Full Set. The keypads give a double "beep" confirmation tone at the end of all setting modes, including Silent Set. The default is option 0, Timed.

Option

- 0 Timed. Use this option if the system sets after an exit time selected using Command 44. If an Exit Terminate button is fitted, the user may use it to shorten the exit time.
- 1 Terminated. Use this option if the user completes setting the system by pushing an Exit Terminate button connected to a keypad. The exit time is infinite in this option. The system sets 7–12 seconds after the completed action; the delay is set with Command 182 (see page 59).
- 2 Final Door Set. Use this option to complete setting of the system by closing a door fitted with a Final Exit zone detector. The exit time is infinite in this option. The system sets 7–12 seconds after the completed action; the delay is set with Command 182 (see page 59).
- 3 Lock Set. To use this option, you must install a lock switch and connect its contacts to the ET terminals of a keypad (refer to the *9x5x Installation Guide*). This facility is available on keypad software version 1.4.2 onwards. See the notes below for more information.

Notes on Lock Set:

- 1. Do not connect more than one lock switch (or any other device) to the keypad ET terminals. Do not attempt to fit two lock switches.*
- 2. To set the system, the user first enters their access code at a keypad or operates a keyswitch. The control unit starts to emit the exit tone. The exit time is infinite in this option. The user then operates the Final Exit zone and turns the key in the lock switch to "locked". The system sets 7–12 seconds after the lock switch contacts open; the delay is set with Command 182 (see page 59).*
- 3. To unset the system, the user turns the lock switch to "unlocked" (which closes the contacts). The keypads start to emit a continuous tone; this is not affected by PD6662 / pr EN 50131-1: 2004, as the possession of a key indicates an authorised user. At this point, the user can lock the lock switch again without causing an alarm. When the user opens the Final Exit zone, the control unit starts the entry timer. The user completes entry by unsetting the system in the normal way.*
- 4. If an intruder opens the Final Exit door without first unlocking the lock switch, the control unit immediately starts an alarm.*

40: System Auto Rearm

This command sets the number of times that the system will rearm all closed zones when the bell duration expires. If you select option 0, the system will not rearm (it will go into alarm only once). Select option 1 to rearm once, 2 to rearm twice, 3 to rearm three times or 4 to rearm every time the bell duration expires.

Use this command in conjunction with Command 35, First Circuit Lockout.

If the system has rearmed, the control unit gives an audible internal alarm instead of the normal entry tone when a user enters the premises through the Entry Route.

41: Bell Delay

When an alarm occurs (for example, an intruder violates a zone), the system waits for the Bell Delay before operating the external sounder for the Bell Duration. This command sets the Bell Delay.

Note: a) Command 41 has no effect if Alarm Confirmation (Command 89) is enabled.
b) Compliance with PD 6662 / prEN 50131-1: 2004 (see page 68) requires that the Bell Delay does not exceed 10 minutes and that it is not used for entry alarms.

Option

- | | |
|---|--------------------|
| 0 | No delay (default) |
| 1 | 1.5 minutes |
| 2 | 3 minutes |
| 3 | 5 minutes |
| 4 | 10 minutes |
| 5 | 15 minutes |
| 6 | 20 minutes |

42: Bell Duration

When an alarm occurs (for example, an intruder violates a zone), the system waits for the Bell Delay before operating the external sounder for the Bell Duration. This command sets the Bell Duration.

Note: Compliance with PD 6662 / prEN 50131-1: 2004 (see page 68) requires that the Bell Duration does not exceed 15 minutes.

Option

- | | |
|---|----------------------|
| 1 | 1.5 minutes |
| 2 | 3 minutes |
| 3 | 5 minutes |
| 4 | 10 minutes |
| 5 | 15 minutes (default) |
| 6 | 20 minutes |

44: Level A Exit Time

This command lets you set the Exit Time for Full Set.

Option

- | | |
|---|----------------------|
| 1 | 10 seconds |
| 2 | 20 seconds (default) |

3	30 seconds
4	45 seconds
5	60 seconds
6	120 seconds

45: Entry/Exit Tone Volume

This command sets the volume of the Entry/Exit tone from the internal sounder. If you select option 0, the internal sounder emits no tone. Select a value from 1 (quietest) to 9 (loudest) to set the volume (default 5). The internal sounder demonstrates the volume when you enter the digit.

46: Tamper Alarm Response

This command specifies which sounders the control unit will activate for a Tamper Alarm while the system is unset.

Option

0	Internal sounders only (default)
1	Keypad sounders only
2	Internal and keypad sounders

48: Lockout Keypads During Entry

This command enables you to lock keypads during entry when proximity tag readers or remote setting devices are being used to unset the system. When you lock keypads during entry, some functions are still available:

- Keypad PA, Fire and Medical alarms
- Duress Code operation
- User's ability to cancel false alarms or disarm the system during an alarm.

If you select option 0, the system permits all users to use all keypads during entry. If you select option 1, the system locks all users out of all keypads during entry (not required for Grade 2x installations).

49: Duress Code

This command selects whether the control unit supports a Duress Code (set by the master user as described in the *9651 User Guide*). Entering this code will cause a silent communication to be sent to the Alarm Receiving Centre (ARC) if a user is forced to unset the system by an intruder.

A duress restore is communicated on the first occasion that a normal user access code is entered after the duress code has been used.

Option

0	Off (default). No Duress Code.
---	--------------------------------

1 On. Duress Code.

Note: If the duress code is disabled and then enabled again, the code previously assigned to it by the user will be lost. A new duress code must be assigned.

50: CSID Code

To enable the user to use the "Remote Reset" facility (enabled with Command 23), you must program the control unit as "Engineer Reset" (Command 33 option 1) and install a four-digit Central Station Identification (CSID) code:

1. Contact the Alarm Receiving Centre (ARC) and obtain the CSID code.
2. Ensure that the system is in installer mode.
3. Select Command 50 and enter the four-digit CSID code.

The control unit now contains the same CSID code as the ARC and can use this to generate a four-digit reset code that will be recognised by the ARC 7300 Remote Reset decode programmer.

After an alarm, the user keys in their access code to silence the alarm but cannot reset the system. The system generates the reset code and displays it on the keypad. The user calls the ARC and reports the reset code. The ARC verifies the user's identity and then enters the reset code into the 7300 programmer, which generates an anti-code. The ARC gives the anti-code to the user, who keys it into the keypad to reset the system.

Note: To delete a CSID code, key in "0000" over the existing code.

51: Set Time and Date

The system has an internal clock/calendar, which it uses to record the time and date of events in the log. This command sets the current time and date in the clock/calendar. The system displays the date first: enter the day, month and year in turn, each as two digits. The system then displays the time: enter the hours and minutes in turn, each as two digits (using the 24-hour clock).

52: Omit Alarm

This command specifies whether, when a user omits a zone, the control unit omits the tamper contacts as well as the alarm contacts.

Option

- 0 The control unit omits alarm contacts only.
- 1 The control unit omits both alarm and tamper contacts.

Note: To permit the user to omit a zone, you must set attribute ✕4 for the zone.

53: Abort User/Engineer Reset

This command specifies how the system is reset after an aborted alarm.

Option

- 0 Use the reset option selected for the system with Command 33 (default).
- 1 Permit the user to reset after an abort.

56: Number of Digits in Access Codes

The control unit can use either four-digit or six-digit access codes. Select option 0 for four-digit access codes and option 1 for six-digit access codes. Changing code length causes the system to revert to factory defaults for all access codes; four-digit defaults are 1234 (user) and 7890 (engineer), six-digit defaults are 123456 (user) and 567890 (engineer).

Note: Compliance with PD 6662 / prEN 50131-1: 2004 Grade 2 (see page 68) require option 1; this applies even if you are using proximity tags because the installer and master user will still use access codes. Grade 1 permits either option.

58: Day Tamper User/Engineer Reset

To require an engineer to reset a tamper indication while the system is unset, select option 1. To permit a user to reset a tamper indication in this situation, select option 0 (the default). Irrespective of this setting, the user can continue to set and unset the system while a tamper indication is being displayed.

Notes:

1. *Command 58 was originally used to achieve BVVO compliance.*
2. *Use Command 38 to allow a user reset after a system tamper alarm.*

59: External Sounder Tamper

This command specifies which one of two tamper arrangements is used to connect the control unit to the external sounders. Select the appropriate option for the sounder fitted to the system.

Option

- 0 Tamper return uses negative voltage (default).
- 1 Tamper return is terminated with a 2k2 resistance.

60: Level B Final Exit Operation

In a single system, this command specifies how the system treats Final Exit zones during part set B. If you select option 0 (the default), Final Exit zones included in Level B continue to act as Final Exit zones during part set B. If you select option 1, these zones act as Normal Alarm zones during part set B.

61: Level B Entry Route Operation

In a single system, this command specifies how the system treats Entry Route zones during part set B. If you select option 0 (the default), Entry Route zones included in Level B continue to act as Entry Routes during part set B. If you select option 1, these zones act as Final Exit zones during part set B.

62: Level B Exit Mode

This command sets the exit mode for Level B. The keypads give a double "beep" confirmation tone at the end of all setting modes, including Silent Set. The default is option 0, Timed.

Option

- 0 Timed. The keypad sounders and any internal sounders give a low tone during exit of Level B. Use Command 65 to select the exit time.
- 1 Instant Set (no exit tone). Use this option to make the system set without delay or exit tone.
- 2 Silent Set. Use this option to make the system set without an exit tone. Use Command 65 to program the exit time.
- 3 Makes the Level B exit mode the same as Level A.

63: Level B Alarm Response

This command sets the alarm response for Level B.

Option

- 0 Keypad sounders only.
- 1 Internal sounders and keypad sounders (default).
- 2 Local alarm (internal and external sounder only).
- 3 Full alarm (communication and internal/external sounders).

65: Level B Exit Time

This command sets the Exit Time for Level B.

Option

- 1 10 seconds
- 2 20 seconds (default)
- 3 30 seconds
- 4 45 seconds
- 5 60 seconds
- 6 120 seconds

67: Forbikobler Approved

This command specifies whether the Forbikobler system should operate in an approved manner (user codes only) or a non-approved manner (proximity tags and user codes).

Option

- 0 Non-approved
- 1 Approved (default)

68: Forbikobler Door Timer

This command sets the time that the Forbikobler system allows for entry to the building (not the time needed to unset the system). During this period, an optional output is activated to operate an electromechanical lock on the door.

Option

- | | | | |
|---|---------------------|---|-------------|
| 0 | 2 seconds | 5 | 20 seconds |
| 1 | 3 seconds | 6 | 30 seconds |
| 2 | 4 seconds | 7 | 60 seconds |
| 3 | 5 seconds (default) | 8 | 120 seconds |
| 4 | 10 seconds | 9 | 255 seconds |

69: Forbikobler Door Locking

This command specifies whether the door controlled by the Forbikobler system is normally unlocked while the system is reset or opened only for a controlled time. Even if the door is normally unlocked, it can be locked with a user command if required.

Option

- 0 Lock Timed (default)
- 1 Lock Toggled

70: Level C Final Exit Operation

This command specifies how the system treats Final Exit zones during part set C. If you select option 0 (the default), any Final Exit zones in Level C continue to act as Final Exit zones during part set C. If you select option 1, these zones act as Normal Alarm zones during part set C.

71: Level C Entry Route Operation

This command specifies how the system treats Entry Route zones during part set C. If you select option 0 (the default), any Entry Route zones in Level C continue to act as Entry Routes during part set C. If you select option 1, these zones act as Final Exit zones during part set C.

72: Level C Exit Mode

This command sets the Exit Mode for Level C. The keypads give a double "beep" confirmation tone at the end of all setting modes, including Silent Set. The default is option 0, Timed.

Option

- 0 Timed. The keypad sounders and any internal sounders give a low tone during exit of Level C. Use Command 75 to select the exit time.
- 1 Instant Set (no exit tone). Use this option to make the system set without delay or exit tone.
- 2 Silent Set. Use this option to make the system set without an exit tone. Use Command 75 to program the exit time.
- 3 Makes the Level C exit mode the same as Level A.

73: Level C Alarm Response

This command sets the Alarm Response for Level C.

Option

- 0 Keypad sounders only.
- 1 Internal sounders and keypad sounders (default).
- 2 Local alarm (internal and external sounder only).
- 3 Full alarm (communication and internal/external sounders).

75: Level C Exit Time

This command sets the Exit Time for Level C.

Option

- 1 10 seconds
- 2 20 seconds (default)
- 3 30 seconds
- 4 45 seconds
- 5 60 seconds
- 6 120 seconds

76: Level D Exit Mode

This command sets the Exit Mode for Level D. The keypads give a double "beep" confirmation tone at the end of all setting modes, including Silent Set. The default is option 0, Timed.

Option

- 0 Timed. The keypad sounders and any internal sounders give a low tone during exit of Level D. Use Command 79 to select the exit time.
- 1 Instant Set (no exit tone). Use this option to make the system set without delay or exit tone.
- 2 Silent Set. Use this option to make the system set without an exit tone. Use Command 79 to program the exit time.
- 3 Makes the Level D exit mode the same as Level A.

77: Level D Alarm Response

This command sets the Alarm Response for Level D.

Option

- 0 Keypad sounders only.
- 1 Internal sounders and keypad sounders (default).
- 2 Local alarm (internal and external sounder only).
- 3 Full alarm (communication and internal/external sounders).

79: Level D Exit Time

This command sets the Exit Time for Level D.

Option

- 1 10 seconds
- 2 20 seconds (default)

- 3 30 seconds
- 4 45 seconds
- 5 60 seconds
- 6 120 seconds

Note: You cannot change the operation of Final Exit and Entry Route zones assigned to Level D as you can with Levels B and C (see Commands 60, 61, 70 and 71). For this reason, Cooper Security recommends that you use Level D for simple applications only.

80: Forbikobler Chime

This command links the bell push on the Forbikobler keypad to the Chime on the system, so that pressing the bell operates the sounders.

Option

- 0 Off. Pressing the bell push does not operate the sounders (default).
- 1 On. Pressing the bell push operates the sounders.

81 to 83: Output n Type

These commands select types for the control unit's panel outputs. They take two digits to select the type (see below) and have the following defaults:

Command	Output	Default outputs
81	1	00 Bell
82	2	08 Strobe
83	3	03 Set Latch

Notes: The panel outputs can be tested using Command 91 (page 52a).

Option

- 00 Bell: active during an alarm. Use Command 41 to set Bell Delay and 42 to set Bell Duration. If Alarm Confirmation (Command 89) is enabled, use Command 162 to set whether the bell is sounded on the first or confirmed alarm.
- 01 EE Follow: active when Entry or Exit Time starts and inactive when the time expires or is terminated. The output can be used for a separate Entry/Exit buzzer. It will not give a tone during part set if the exit mode is silent set or instant set.
- 02 Armed Lamp: active continuously while the system is full or part set.

- 03 Set Latch: active when the system is set and inactive when the system is unset or an alarm condition occurs. It is active for one second when a reset is performed or the control unit leaves installer mode. It is also active during Walk Tests.
- 04 Shock Reset: used to reset shock sensors (for example, the "Viper"). The output is triggered by the control unit at the start of the Exit Time and remains active for five seconds.
- 05 Walk Test: active during both engineer and user Walk Tests and during the time between silencing and resetting the system. It is used on movement detectors that are able to switch off the Walk Test lamp in any state other than a Walk Test.
- 06 Ready Lamp: active when the system is unset and if there are no faults. It is inactive when the system is full or part set, during any alarm or if a circuit fault prevents setting. It is also active when the control unit is in installer mode.
- 07 24-hour Alarm: activated when a zone designated as 24-hour is violated and deactivated when the system is disarmed.
- 08 Strobe: activated during an alarm and deactivated when the system is disarmed.
- 09 Smoke Reset: designed to be connected to low-voltage smoke detector reset terminals. It is active for 3 seconds when the system is reset after an alarm.
- 10 Siren Test: activated when the user performs a sounder test.
- 11 Strobe Set A: active for 10 seconds after the system is set. It can be used to operate the Strobe output to give a visual indication that the system has completed setting.
- 12 Pulse Set 1: active for the time set by Command 170 when someone sets the system (same as type 26).
- 13 Pulse Unset 1: active for the time set by Command 172 when someone unsets the system and during a Fire alarm or PA (same as type 30).
- 14 Confirm.
- 15 Set Complete: active for 10 seconds after someone sets the system.
- 16 Unset Complete: active for 10 seconds after someone unsets the system or disarms it after an alarm.
- 26 Pulse Set 1: active for time set by Command 170.
- 27 Pulse Set 2: active for time set by Command 170.
- 28 Pulse Set 3: active for time set by Command 170.

- 29 Pulse Set 4: active for time set by Command 170.
- 30 Pulse Unset 1: active for time set by Command 172.
- 31 Pulse Unset 2: active for time set by Command 172.
- 32 Pulse Unset 3: active for time set by Command 172.
- 33 Pulse Unset 4: active for time set by Command 172.
- 34 Fire: active during a Fire alarm.
- 35 PA: active during a PA.
- 36 Set Fail: active for 60 seconds from when a set command fails.
- 37 General Fault: active for all faults except AC Fail, Anti-Mask, Battery Fault, Line Fault, Zone AC Fail, Zone Battery Fault and Zone Low Battery.
- 38 All Fault: active for all faults (including AC Fail, Anti-Mask, Aux DC, Battery Load Test Fail, Battery Missing, Comms Fail, Keypad Ident Fail, Line Fail, Low Battery, Plugby Fail, uCom Fail, Zone AC Fail, Zone Battery Fault, Zone Fault, Zone Low Battery and Zone Pwr O/P).

85: Burglar Communication Rearm

This command determines what happens to the "burg" communications output (or channel) at the end of the bell run time.

Option

- 0 Latched (default). The output stays active until an engineer or user resets the system.
- 1 Rearm. The system turns off the "burg" channel when the bell run time has expired. Once the channel is inactive, the system is ready to report any new alarm.

Notes:

1. *Ensure that Command 40 System Auto Rearm is set to 1, 2, 3 or 4 in order to enable Command 85.*
2. *If Alarm Abort is enabled (Command 36, option 1), the "burg" channel restores if the user unsets the system.*

87: Keypad Dual Key Alarms

This command enables users to raise an alarm by pressing two keys on the keypad at the same time. Three types of alarms are available, each of which can be enabled or disabled independently. The default is disabled (option 0).

Alarm type	Key combination	Disable	Enable
PA	1 and 3	0	1
Medical	4 and 6	0	1
Fire	7 and 9	0	1

Press A and B to scroll up and down through the types (PA, FI and MD).

Note: Selecting option 1 also enables any PAs connected to 9941 or 9943 keypads.

88: Anti Masking

Do not use.

89: Alarm Confirmation

Use this command to select if alarms are confirmed and, if so, how this is done. Your local Police Intruder Alarms Policy may require alarms to be confirmed.

Option

- 0 None: alarm is communicated when one zone is activated (default outside the UK).
- 1 UK (DD 243): alarm is not communicated until a second zone is activated within 30 minutes of the first (default in the UK).
- 2 2Zn: alarm is communicated when any two zones are activated at any time while the system is set.

Note:

1. *Compliance with DD 243: 2004 requires that Command 89 is set to option 1.*
2. *Activating entry zones during the entry time will not cause or confirm an alarm.*

90: Event Log

For information on this command, see page 63.

91 to 96: Testing Outputs

For information on these commands, see page 66.

97: Engineer Walk Test

For information on this command, see page 66.

98: Load Full Defaults

This command loads the original default values for all commands (for more information, see page 28).

99: Leave Installer Mode

This command returns to user mode (for more information, see page 27).

106: Line Fault Response

This command sets how the control unit responds when it detects a fault on an attached plug by communicator. The response depends on whether the system is set or unset.

Option

0 Not used.

1 Audible (default).

If the system is unset, the control unit logs the event and the keypads emit a short audible tone every minute. Entering a valid access code silences the sounders and the keypad displays indicate a telephone line fault. The system can be set again with the line fault present.

If the system is set, the control unit logs the event but the keypads do not emit a tone or display a message. If the line is out of order when an alarm occurs, the control unit cancels any programmed Bell Delay.

Note: Compliance with the NSI recommendation requires option 1.

2 Silent.

If the system is unset, the control unit logs the event and the keypad displays indicate a telephone line fault (without giving any audible warning). The system may be set again with the line fault present.

If the system is set, the control unit logs the event but the keypads do not display a message. If the line is out of order when an alarm occurs, the control unit cancels any programmed Bell Delay.

126: Select Language

The control unit can display messages on the keypads in several languages. Select option for the language you wish to use:

- | | | | |
|---|-------------------|----|-------------------|
| 0 | English (default) | 6 | Deutsch (German) |
| 1 | Italian | 7 | Norsk (Norwegian) |
| 2 | Espanol (Spanish) | 8 | Svenska (Swedish) |
| 3 | Port (Portuguese) | 9 | Dansk (Danish) |
| 4 | Nederl (Dutch) | ✕1 | Suomi (Finnish) |
| 5 | Francai (French) | | |

Note: This overrides the default language loaded when the Country is selected with Command 0.

134: AC Fail User/Installer Reset

Use this command to determine how AC Fail alerts are reset.

Option

- 0 No Reset Required (default). An alert is generated when the mains power supply fails and reset automatically when the supply is restored.
- 1 User Reset. An alert is generated when the mains power supply fails and can be reset by the user or installer when the supply is restored.

- 2 Installer Reset. An alert is generated when the mains power supply fails and can be cleared only by the installer when the supply is restored.

Note: Compliance with PD 6662 / prEN 50131-1: 2004 (see page 68) requires that Command 134 is set to 1 or 2 (Cooper Security recommends 1).

135: Line Fault User/Installer Reset

Use this command to determine how Line Fault alerts are reset.

Option

- 0 No Reset Required (default). An alert is generated when a line fault occurs and reset automatically when the fault is cleared.
- 1 User Reset. An alert is generated when a line fault occurs and can be reset by the user or installer when the fault is cleared.
- 2 Installer Reset. An alert is generated when a line fault occurs and can be cleared only by the installer when the fault is cleared.

Note: Compliance with PD 6662 / prEN 50131-1: 2004 (see page 68) requires that Command 135 is set to 1 or 2 (Cooper Security recommends 1).

136: Anti-Mask User/Installer Reset

Use this command to determine how Anti-Mask alerts are reset.

Option

- 0 User Reset (default). Anti-Mask alerts can be reset by the user or installer.
- 1 Installer Reset. Anti-Mask alerts can be cleared only by the installer.

137: AC Fail Override

Use this command to determine how AC Fail alerts can be overridden.

Option

- 0 Never. The user cannot override AC Fail alerts when setting the system and must first reset them. Command 134 determines how the alert can be reset.
- 1 Inactive. The user can override AC Fail alerts when setting the system, provided that the power supply has been restored.
- 2 Any (default). The user can override AC Fail alerts when setting the system.

Note: Insurance policies that are conditional on compliance with PD 6662 / prEN 50131-1: 2004 (see page 68) may require that Command 137 is set to 1 or 2 to restrict the user's ability to override alerts.

138: Line Fault Override

Use this command to determine how Line Fault alerts can be overridden.

Option

- 0 Never. The user cannot override Line Fault alerts when setting the system and must first reset them. Command 135 determines how the alerts can be reset.
- 1 Single. Not used in 9651.
- 2 Any (default). The user can override any number of Line Fault alerts when setting the system.

Note: Insurance policies that are conditional on compliance with PD 6662 / prEN 50131-1: 2004 (see page 68) may require that Command 138 is set to 1 or 2 to restrict the user's ability to override alerts.

139: Fault User/Installer Reset

Use this command to determine how alerts can be reset for all faults that do not have an individual reset command.

Option

- 0 User Reset (default). Fault alerts can be reset by the user or installer.
- 1 Installer Reset. Fault alerts can be cleared only by the installer.

Notes:

1. *Resets faults including AC Fail, Aux DC, Battery Load Test Fail, Battery Missing, Comms Fail, Keypad Ident Fail, Line Fail, Low Battery, Plugby Fail, uCom Fail, Zone AC Fail, Zone Battery Fault, Zone Fault, Zone Low Battery and Zone Pwr O/P.*
2. *Insurance policies that are conditional on compliance with PD 6662 / prEN 50131-1: 2004 (see page 68) may require that Command 139 is set to 1 to restrict the user's ability to override alerts.*

140: Fault Override

Use this command to determine how alerts can be overridden for all faults that do not have an individual override command.

Option

- 0 Never (default). The user cannot override a Fault alert when setting the system.
- 1 Inactive. The user can override a Fault alert when setting the system, provided that the cause of the fault has been rectified.

Note: Overrides faults including AC Fail, Aux DC, Battery Load Test Fail, Battery Missing, Comms Fail, Keypad Ident Fail, Line Fail, Low Battery, Plugby Fail, uCom Fail, Zone AC Fail, Zone Battery Fault, Zone Fault, Zone Low Battery and Zone Pwr O/P.

141: Alert Tone On/Off

Use this command to disable the Alert fault tones. When enabled (default) the system gives an alert tone and displays alerts on the keypad.

Option

- 0 Disabled. The display shows alert messages for faults, but does not sound alert tones.
- 1 Enabled (default). The display shows alert messages, and the system gives alert tones.

151 to 158: Plug-by Communicator Outputs

These commands select types for the control unit's programmable outputs, which can be used to control a plug-by communicator. The 9651 provides eight programmable outputs on the main circuit board. The outputs can be connected to the communicator by a wiring harness provided with the control unit (refer to the *9x5x Installation Guide* for details). The commands take two digits to select the type and have the following defaults:

Command	Output	Default type
151	1	01 Fire
152	2	02 PA
153	3	03 Burglar
154	4	04 Open/Close
155	5	15 Zone Omitted
156	6	05 Alarm Abort
157	7	Not used
158	8	06 Technical Alarm

Option

00	Not Used	19	Smoke Detector
01	Fire	20	Not used
02	PA	21	Battery Fault
03	Burglar	22	System Alarm
04	Open/Close	27	Not used
05	Alarm Abort	28	Not used
06	Technical Alarm	29	Not used
07	Confirmed	30	Pulse Set OP 1
08	Not Used	31	Pulse Set OP 2
09	Not Used	32	Pulse Set OP 3
10	Not Used	33	Pulse Set OP 4
11	AC Fail	34	Pulse Unset OP 1
12	Tamper Alarm (day tamper)	35	Pulse Unset OP 2
13	Open	36	Pulse Unset OP 3
14	Close	37	Pulse Unset OP 4
15	Zone Omitted	38	Set Fail
16	Medical Assistance	39	General Fault (Note 2)
17	Key Box	40	All Fault (Note 3)
18	Anti-Mask	41	Duress

Notes:

1. *General Fault is active for all faults except AC Fail, Anti-Mask, Battery Fault, Line Fault, Zone AC Fail, Zone Battery Fault and Zone Low Battery.*
2. *All Fault is active for all faults (including AC Fail, Anti-Mask, Aux DC, Battery Load Test Fail, Battery Missing, Comms Fail, Keypad Ident Fail, Line Fail, Low Battery, Plugby Fail, uCom Fail, Zone AC Fail, Zone Battery Fault, Zone Fault, Zone Low Battery and Zone Pwr O/P).*
3. *The control unit delays reporting/logging either mains loss, or exiting engineering with mains loss, by 15-18 min (chosen at random). If you select a Scandinavian default in Command 0, the control unit waits at least 60 minutes before reporting.*
4. *The plug-by outputs can be tested using Command 92 (page 52a).*

159: Invert Plug-by Outputs

By default, plug-by outputs have a positive voltage when inactive and this is removed when the output is active. This command inverts that logic so that a positive voltage is applied when the output is active.

Option

- 0 +ve removed to trigger (default): the output is positive when inactive and goes to zero when active.
- 1 +ve applied to trigger: the output floats when inactive and goes positive when active.

160: Confirmed Alarm Timer

Note: Set Alarm Confirmation (Command 89) to 1 to access this command.

This command controls a timer, which starts when an alarm is triggered for the first time. If a second alarm is triggered before the timer expires, the control unit transmits a confirmed alarm to the Alarm Receiving Centre (ARC). You can set the timer to any value between 001 and 999 minutes (default 30).

Note: Compliance with DD 243: 2004 requires that Command 160 is set to a value of 30 to 60 minutes.

161: Internal Sounder on Confirmed or Unconfirmed Alarm

Note: Set Alarm Confirmation (Command 89) to 1 or 2 to access this command.

This command selects whether the control unit will operate the internal sounder for a confirmed alarm or for an unconfirmed alarm. In a partitioned system, the internal sounder is available only for Partition A; other partitions use keypad sounders only.

Option

- 0 Control unit operates the internal sounder for a confirmed or unconfirmed alarm (default).
- 1 Control unit operates the internal sounder only for a confirmed alarm.

Note: Compliance with DD 243: 2004 requires that Command 161 is set to 0.

162: External Sounder on Confirmed or Unconfirmed Alarm

Note: Set Alarm Confirmation (Command 89) to 1 or 2 to access this command.

This command selects whether the control unit will operate the external sounder for a confirmed alarm or for an unconfirmed alarm.

Option

- 0 Control unit operates the external sounder for a confirmed or unconfirmed alarm (default).
- 1 Control unit operates the external sounder only for a confirmed alarm.

Note: Compliance with DD 243: 2004 requires that Command 162 is set to 0.

163: Confirmed Alarm during Entry

Note: Set Alarm Confirmation (Command 89) to 1 or 2 to access this command.

This commands controls how the system treats alarms that arise during entry. The options select the number of non-Entry Route zones that must be triggered to provide a confirmed alarm after the entry time.

Option

- 0 Never (default). Alarm Confirmation is disabled after entry.
- 1 One zone.
- 2 Two zones.

Note 1: Compliance with DD 243: 2004 requires that Command 163 is set to 0.

Note 2: Compliance with DD 243: 2004 requires that Command 163 is not set to 1 (setting to 0 to comply with Note 1 is acceptable).

Option 0 ensures that you will never get a confirmed alarm after the start of the entry timer. Select this to comply with DD 243 sections 6.4.2, 6.4.3, 6.4.4 and 6.4.6, which cover entry methods where:

- Unlocking the final door unsets the system.
- Unlocking the final door disables confirmation.
- Opening the entry door disables confirmation.
- The user must call the Alarm Receiving Centre (ARC) to unset the system.

Select option 2 to comply with DD243: 2004 section 6.4.5, which covers unsetting the system with an item of portable alarm communication equipment (for example, a proximity reader or telecommand).

164: User/Engineer Reset after Confirmed Alarm

Note: Set Alarm Confirmation (Command 89) to 1 or 2 and Enable Engineer Reset (Command 33) to access this command.

Use this command to select who can reset the system after a confirmed alarm.

Option

- 0 User/Engineer (default). The user can reset the system after a first alarm but an engineer is required to reset after a confirmed alarm.
- 1 User/User. The user can reset the system after both types of alarm.
- 2 Engineer/Engineer. An engineer is required to reset the system after both types of alarm.

Note: Compliance with DD 243: 2004 requires that Command 164 is set to:

(a) option 0 or 2 for sections 6.4.4 and 6.4.5 or (b) option 1 for sections 6.4.2, 6.4.3 and 6.4.6. This means that a user cannot reset the system after a confirmed alarm unless the system is unset using a keyswitch, lockswitch or by calling an Alarm Receiving Centre (ARC).

170 to 175: Pulse Output Programming

You can program the panel outputs to generate a pulse of a defined length when triggered by a set or unset event. Pulses of different lengths can be set for each level. Commands 170 to 175 enable you to configure these pulse outputs. Press ✓ to move between the outputs within each command.

Command	Value	Default	Description
170	00* to 12	01	Specifies the length in seconds of the pulse to be generated on setting. * A value of 00 latches the output.
171	A/B/C/D	abcd	Assigns each pulse set output to one or more levels.
172	00* to 12	01	Specifies the length in seconds of the pulse to be generated on unsetting. * A value of 00 latches the output.
173	A/B/C/D	abcd	Assigns each pulse unset output to one or more levels.
174	0 (Off) or 1 (On)	On	Specifies whether each pulse unset output is activated for a Fire alarm.
175	0 (Off) or 1 (On)	On	Specifies whether each pulse unset output is activated for a PA.

Notes:

1. *Generating a pulse on an output depends both on a set or unset pulse being defined for the output and on the output being associated with a level that is being armed or disarmed.*
2. *Commands 174 (Fire) and 175 (PA) activate only the Pulse Unset outputs configured with Command 172.*

Example 1

Panel output 3 is to be programmed as type 12 (Pulse Set 1). It will be used to operate a locking mechanism when the whole system is set. The locking mechanism requires a 6-second pulse. The table below shows how to program the system to generate the required pulse.

Command	Value	Description
83	12	Sets panel output 3 to type Pulse Set 1.
170	Set 1 = 06	Sets the duration of Pulse Set 1 to 6 seconds.
171	Set 1 = a	Allocates Pulse Set 1 to Level A .

182: Set Final Exit Settling Time

This command defines a time delay to allow detectors to settle before the system sets. This may be needed if detectors are being set off by air movements caused by the final door being closed. During this period, the sounders stop and the system sets but the control unit ignores any alarms generated by the detectors.

Enter two digits to specify a time in seconds, from 07 to 12 (default is 07).

183: Set Display Line 2

This command sets the message that the control unit shows on the second line of keypad displays in user mode. Key in a message of up to 16 characters ("Zone Names" on page 30 explains how to enter characters). The default text identifies the control unit model used in the system.

184: Pulsed External Sounder for Fire

This command instructs the control unit to send a pulse to bell-type panel outputs (configured with Commands 81–83, option 00) to signal a Fire alarm. This can be used to drive the external sounders, giving a different alarm sound from the normal continuous bell tone.

Option

- 0 Off (default). Use normal two-tone Fire alarm.
- 1 On. Send a pulse to bell-type outputs in the system.

185: Keyswitch Auto Reset

This command instructs the control unit to reset automatically if the user uses the keyswitch to set the system on leaving.

Option

- 0 Off (default). User must reset manually.
- 1 On. System resets automatically when the user sets it with a keyswitch (KM or KF).

Note: Compliance with PD 6662 / prEN 50131-1: 2004 (see page 68) requires that Command 185 is set to option 0.

199: Display Zone Circuit Resistance

For information on this command, see page 67.

200: Forbikobler Entry Timer

This command sets the interval between a user entering the premises through a Forbikobler entrance and an alarm going off, using one of the independent entry timers configured with Commands 201 to 204. Any of the entry timers can be assigned to any Forbikobler entrance. Entering the entry code into the Forbikobler unit starts the selected entry timer.

Option

- 1 Entry Timer 1 (default)
- 2 Entry Timer 2
- 3 Entry Timer 3
- 4 Entry Timer 4

201 to 204: Entry Timers 1 to 4

Entry timers set the interval between a user entering the premises and an alarm going off. There are four independent entry timers so that you can set different intervals for different entrances, reflecting the time required to complete each entry route.

Note: These replace the level-specific timers available on earlier control units (formerly set with Commands 43, 64, 74 and 78). They provide a more flexible approach to timed entry routes, enabling any timer to be selected for any entrance.

Each entry timer can be assigned to any zone of types FE (Final Exit), ER (Entry Route) and FB (Forbikobler), using the zone programming commands 01 to 08 (see page 30). Set zone attribute ✕7 to a value between one and four to select the required entry timer. Opening the zone starts the selected entry timer.

Note: Compliance with PD 6662 / prEN 50131-1: 2004 (see page 68) requires that the Entry Timer does not exceed 45 seconds.

Option

- | | |
|---|----------------------|
| 1 | 10 seconds |
| 2 | 20 seconds (default) |
| 3 | 30 seconds |
| 4 | 45 seconds |
| 5 | 60 seconds |
| 6 | 120 seconds |

Note: By default, Entry Timer 1 is assigned to all relevant zones.

Setting Different Entry Timers for Different Entrances

Suppose that you have installed a system on a site that can be entered through a front door or through an integral garage with an internal door:

- When a user opens the front door, it may take only 20 seconds to step inside and enter an access code at a keypad in the lobby.
- By contrast, when the user drives in through the garage door and opens the external door (starting the entry timer), it may then take 120 seconds to park the car, get out, lock the car, unlock the internal door, go inside and enter an access code at the keypad.

Irrespective of levels, you can set one entry timer to 20 seconds and assign it to the front door, and set another entry timer to 120 seconds and assign it to the garage door.

To set up such a system:

1. Set Entry Timer 1 to 20 seconds: Command 201, option 2 (default).
2. Set Entry Timer 2 to 120 seconds: Command 202, option 6.
3. Set up an FE zone for the front door and use **✕7** to select Entry Timer 1: for example, zone 10 with type set to 05 (FE) and attribute **✕7** set to 1 (Entry Timer 1).
4. Set up an FE zone for the garage door and use **✕7** to select Entry Timer 2: for example, zone 11 with type set to 05 (FE) and attribute **✕7** set to 2 (Entry Timer 2).

The same principle applies equally well in any other situation where there are multiple entrances with entry routes of different lengths. Managing entry timers in this way enables you to assign the most appropriate of four intervals to each entrance, without being restricted by the way in which you have set up your levels.

Setting Entry Timers for both FE and ER Zones

Suppose that you have installed a system that uses the Final Door exit mode. In this case, the entry timer will usually be started when a user opens the final door. It might seem unnecessary to assign an entry timer to an ER zone set up inside but there are two types of situations which make it useful to do so.

1. In a house where the keypad is near the final door (for example, in the hall), the entry time for a user coming through the door and unsetting the system might be short (for example, 20 seconds). However, if the stairs from the bedrooms descend into the living room (rather than the hall) and you set up a detector there as an ER zone, users coming downstairs in the morning may need longer to reach the keypad and unset the system. Assigning a longer timer to the ER zone allows for this requirement.
2. If a final door develops a fault and has to be omitted from the system, the control unit treats ER zones as FE zones and so they need entry timers.

Testing Commands

90: Reading the Event Log

The control unit keeps a log of recent events. The log can contain up to 700 events. Each event is described by a short text message. To review the event log, make sure the system is in installer mode and then:

1. Key in 90✓.
The display shows the most recent event in the log.
2. Key in 1 to show earlier events or 3 to show later events.
3. Key in 4 to show the first event or 6 to show the last event.
4. Press ✕ to leave the log.

The table on the following pages shows the messages that can be recorded in the event log. Column 1 lists messages shown on the keypad displays.

To avoid multiple entries being made for the same fault condition, no more than three events of the same type will be recorded for the same zone in the same set period.

Note: The log is protected and cannot be erased by the Installer or a user.

In the log, users and devices are represented by numbers:

U00	Installer	U54	N/A
U01	User 01	U55	Keyswitch
U02 to 50	Users 02 to 50	U56	Remote reset
U51	Duress code	U57	N/A
U52	Control unit	U58	N/A
U53	Idle		
		U59	Forbikobler

Event Log Messages

Keypad Display	Meaning
AC Fail	Mains power supply failed
AC Restore	Mains power supply restored
Alarm Abort	User aborted alarm
AntiMask AI Z==	Anti-mask alarm on zone ==
AntiMask Rs Z==	Anti-mask alarm on zone == reset
AntiMask Tp Z==	Tamper on anti-mask zone ==
AUX DC Fail	Auxiliary power failed
AUX DC Fail Rstr	Auxiliary power restored
Bad Checksum	Control unit memory corrupted

Keypad Display	Meaning
Batt Flt Rstr	Battery reconnected
Batt Load Fail	Battery failed load test
Batt Missing	Battery disconnected
Bell Tamper	Sounder tampered with
Bell Tamper Rst	Sounder tamper reset
Burg Z== Alarm	Intruder alarm on zone ==
Burg Z== Rstr	Intruder alarm on zone == reset
Codes Defaulted	Access codes returned to default values
Comms Fail	Communications failure
Config Changed	System configuration (site-specific data) has changed
Defaults Loaded	Default values loaded for all commands
EEPROM Fail	Control unit memory damaged
F== Missing	Forbikobler keypad disconnected
F== Restore	Forbikobler keypad reconnected
F== Tamper	Forbikobler keypad tampered with
Fire Reset	Fire alarm reset
Fire Z== Alarm	Fire alarm on zone ==
Fire Z== Rstr	Fire alarm on zone == restore
Forbi I/F Tamper	Forbikobler interface tampered with
Forbi Lp Tamper	Forbikobler loop tampered with
Fr K== Alarm	Fire alarm started at keypad ==
Frb I/F Tamp Rst	Forbikobler interface tamper reset
Frb Lp Tamp Rst	Forbikobler loop tamper reset
Global T.Restore	Global zone tamper alarm reset
Global Tamper	Global zone tamper alarm
K== Excess Keys	Incorrect access code entered more than four times at keypad ==
K== Missing	Keypad == disconnected
K== Restore	Keypad == reconnected
K== Tamper	Keypad == tampered with
Key Box Cls Z==	Keybox on zone == closed
Key Box Opn Z==	Keybox on zone == open
Key Sw Set #	System set by keyswitch on level #
KeySw Unset #	System unset by keyswitch on level#
Lid Tamp Restore	Control unit lid tamper reset
Lid Tamper	Control unit lid tampered with
Low Batt Rstr	Low battery detected on control unit
Low Batt Rstr Z==	Low battery reset on control unit
Md K== Alarm	Medical alarm started at keypad ==
Override #	Fault overridden in level #
PA K== Alarm	Panic alarm started at keypad ==

Keypad Display	Meaning
PA Z== Alarm	Panic alarm started in zone ==
PA Z== Rstr	Panic alarm reset in zone ==
Set Fail Z==	System failed to set because of fault in zone ==
Smk Det Alm Z==	Smoke detector alarm in zone ==
Smk Det Res Z==	Smoke detector alarm reset zone ==
Soak Fail Z==	Soak test failed in zone ==
System Rearmed	System rearmed after an alarm
System Startup	Power applied to system
System Tamp Rst	System tamper reset
System Tamper	System tamper
Tamper F== Rstr	Forbikobler keypad == tamper reset
Tamper K== Rstr	Keypad == tamper reset
Tamper Z==	Zone == tampered with
Tamper Z==	Tamper in zone == during the day
Tamper Z== Rstr	Zone == tamper reset
Tech Z== Alarm	Technical alarm in zone ==
Tech Z== Rstr	Technical alarm in zone == reset
U== # Set	User == set level #
U== # UnSet	User == unset level #
U== Change U==	User == changed access code for user ==
U== Delete U==	User == deleted access code for user ==
U== Duress	Duress code entered by user ==
U== Off-Site	Installer exited from programming mode
U== On-Site	Installer entered from programming mode
U== System Reset	User – reset system
U== Time/Date	Time and date user reset the system
U== Z== Omit	User omitted zone ==
U== Z== Unomit	User unomitted zone ==
UserCode req off	No user code before installer code
UserCode req on	User code before installer code
XT ACFI Rst Z==	Mains power supply restored in zone ==
XT ACFI Z==	Mains power supply failed in zone ==
XT BatFI Rst Z==	Battery reconnected in zone ==
XT BatFI Z==	Battery fault in zone ==
XT Fault Z== Rst	Zone of type 'Fault' reset
XT Fault Zone ==	Zone of type 'Fault' active
XT PwrFI Rst Z==	Power output fault reset in zone ==
XT PwrFI Z==	Power output fault in zone ==

Keypad Display	Meaning
Z== Lock Out	The system locked out the zone when attempting to rearm at the end of the bell run time.
Z== Lock Out Rst	The system restored a locked out zone zone.

Note: The log is protected and cannot be erased by the Installer or a user.

91 to 96: Testing Outputs

You may test parts of the system by entering commands at the keypad. To carry out a test make sure the system is in installer mode and then key in one of the following commands:

- 91✓ Test normal outputs:
Press keys 1 to 3 to toggle outputs 1 to 3 on and off.
- 92✓ Test plug-by outputs:
Press keys 1 to 8 to toggle outputs 1 to 8 on and off.
- 93✓ Not used.
- 94✓ Test the internal sounder output.
- 95✓ Test the keypad sounder.
- 96✓ Not used.

Press ✓ to end each test. All outputs revert to their former settings.

97: Engineer Walk Test

This function enables the engineer to test all devices on the system.

1. Enter installer mode.
2. Press 97✓
The display shows: 97: Walk Test
3. Open and close each alarm and tamper contact in turn.
The system gives a Chime tone each time you open and close a detector contact. The display shows: "A: Zone" and the zone number of every detector you have tested, in sequence and for one second each. If you also test the tampers on each zone, the display shows the letter "T" against each zone number.
4. Press ✕ to stop the Walk Test.

*Note: The engineer Walk Test enables you to test **all** zones, including PA zones, zone tampers, and control unit and bell tampers. The user Walk Test does not enable you to test tampers or PA, Fire, 24-hour and Technical zones.*

199: Display Zone Circuit Resistance

This command lets you view the resistance of zones connected to the control unit. Either key in the zone number (single digit 1 to 8 only) or press C to step up and A to step down through the zones.

Note: In software version 4.0 use keys 1 and 3 to step through the zones.

The bottom line of the display shows the word "Panel" followed by the zone type, and then the resistance of the zone in kilo Ohms. If the display shows "O/C" then the zone is open circuit. "0k0" means that the zone is short-circuit.

991: Show Software Version

Use this command to show the software version installed within the control unit.

1. Enter installer mode and key in 991 ✓.

The display shows, for example:

9651 v5.00.17

2. Press ✕ to return to Installer Mode.

System Configuration

PD 6662 / prEN 50131-1: 2004 Compliance

EN 50131-1: 2004, *Alarm systems – Intrusions and Hold-up Systems – Part 1: System Requirements*, requires that an alarm system does not display any detailed information until a user enters a valid access code or presents a valid proximity tag. The system should display an alert to inform users that there is information to view. There are four grades of system:

Grade 2X The 9651 control unit can be configured to comply with this grade.

Grade 2 9651 control units are not designed to comply with this grade.

Grade 3 9651 control units are not designed to comply with this grade.

Grade 4 9651 control units are not designed to comply with this grade.

Note: 9651 control units do not reflect variations set out in EN 50131-1:1997.

Programming for Compliance

Use the following setting to ensure compliance with PD 6662 / prEN 50131-1: 2004.

N/A = Not applicable

Command	Grade 1/2	Page	Notes
21	any	35	
27	0	36	
28	2	36	
29	1	37	
37	any	39	
41	≤ 10 min	41	
42	≤ 15 min	41	
56	G1 – any G2 – 1	44	Applies when using proximity tags because the installer and master user still use access codes
63	2	45	
73	2	47	
77	2	48	
134	1/2	53	Option 1 is recommended
135	1/2	54	Option 1 is recommended
137		54	Insurers may require a restriction
138		55	Insurers may require a restriction
139		55	Insurers may require a restriction
140		56	Insurers may require a restriction

Programming Commands Quick Reference

Command	Key in:	Command	Key in:
0	Country PTT Defaults (page 30)	0 ✓/n✓	
n =	Country: 0 = UK		Y
	1 = Italy (I) 2 = Spain (EE) 3 = Portugal (P) 4 = Netherlands (NL) 5 = France (FR) 6 = Belgium (B) 7 = Germany (D) 8 = Switzerland (CH) 9 = Austria (A) X1 = Ireland (IRL) X2 = OEM 1 X3 = OEM 2 X4 = Finland (FI) X5 = Norway (N) X6 = Denmark (DK) X7 = Sweden (S) Note: Executing this command loads all defaults for the selected country.		
01–X40	Zone Programming (page 30)	nn✓/ab	
nn =	Zone number: 01 to 08		
a =	Zone type, one of: 00 = NU (Not Used) 01 = PA (Panic Alarm) 02 = FR (Fire) 03 = NA (Normal Alarm) 04 = 24 (24-hour) 05 = FE (Final Exit) see X7 below 06 = ER (Entry Route) see X7 below 07 = SA (Shock Analyser) see X7 below 08 = TC (Technical Alarm) 09 = KB (Keybox) 10 = SD (Smoke Detector) 11 = KM (Keyswitch Momentary) 12 = KF (Keyswitch Fixed) 13 = AM (Anti-Mask) 14 = FB (Forbikobler) see X7 below 15 = AC (AC Fail) 16 = LB (Low Battery) 17 = BF (Battery Fault) 18 = PF (Power Output Fault) 19 = FL (Fault)		
b =	Zone attributes, any of: X1 = C (Chime) X2 = S (14-day Soak Test) X3 = D (Double Knock) X4 = O (Omit Allowed) X7 = 1–6 or 1–4 For zone type 07, shock analyser sensitivity: 1 (low) to 6 (high) For zone types 05, 06 and 14, entry timer number: 1 to 4 (see Commands 201–4 on page 60) A = a (armed in Level A) B = b (armed in Level B) C = c (armed in Level C) D = d (armed in Level D)		
	<u>Default zone types:</u> Z01=FE abcd 1 Z02=ER abcd 1 Z03-Z07=NA abcd Z08=PA abcd		
	Example: To set Zone 07 as a Normal Alarm, active in Level B and with Omit Allowed. Key in: 07✓/ Zone Number 03 Normal Alarm B Active in Level B X4 Omit Allowed ✓ to store the value of the Command		
20	Change Engineer Code (page 35)	20✓nnnn✓ gggg✓	
nnnn =	New Engineer Code (Code)	7890	
21	Zone Configuration (page 35)	21✓/n✓	
n =	0 Closed circuit tamper (CC+ComA/T) 1 Fully supervised loop (FSL 2K2/4K7)	Y	
22	Loudspeaker Chime (page 35)	22✓/n✓	
n =	Loudspeaker Chime volume 0 Off (keypad only) 1 (minimum) to 9 (maximum)	5	
23	Remote Reset Enable (page 36)	23✓/n✓	
n =	0 Off 1 On Note: Set Command 33 to Option 1 and set a CSID code with Command 50.	Y	
25	Internal Sounder Delay and Duration (page 36)	25✓/n✓	
n =	0 LS Timed (follows external sounder) 1 LS Cont (continuous)	Y	
27	Exit Fault External Sounder (page 36)	27✓/n✓	
n =	0 Internal 1 Local	Y	
28	Status Display (page 36)	28✓/n✓	
n =	0 Status Continuous (always visible) 1 Status Timed (visible for 30s after an event)	Y	
29	Entry Alarm Delay Time (page 37)	29✓/n✓	
n =	0 Delay Off	Y	

Command	Key in:
	1 Delay On
30 PA Response (page 37)	30 ✓n✓
n = 0 PA response audible	Y
1 PA response silent	
31 Zone Tamper User/Engineer Reset (page 38)	31 ✓n✓
n = 0 User reset after zone tamper	Y
1 Engineer reset after zone tamper	
33 System User/Engineer Reset (page 38)	33 ✓n✓
n = 0 User can reset the system	Y
1 Engineer must reset the system	
34 PA User/Engineer Reset (page 38)	34 ✓n✓
n = 0 User reset after PA	Y
1 Engineer reset after PA	
35 First Circuit Lockout (page 38)	35 ✓n✓
n = 0 Lockout first circuit to activate	Y
1 Rearm first circuit to activate	
36 Alarm Abort (page 38)	36 ✓n✓
n = 0 User cannot abort a false alarm	Y
1 User can abort a false alarm	
37 Daytime Tamper Communication (page 39)	37 ✓n✓
n = 0 Internal sounder only	Y
1 Communicate tamper to ARC	
38 System Tamper User/Engineer Reset (page 39)	38 ✓n✓
n = 0 User reset after Tamper Alarm	
1 Engineer reset after Tamper Alarm	Y
39 Level A Exit Mode (page 39)	39 ✓n✓
n = 0 Timed (full tone on setting)	Y
1 Terminated (terminated by button)	
2 Final Door (last door has a detector)	
3 Lock Set (terminated by lock switch)	
40 System Auto Rearm (page 40)	40 ✓n✓
n = 0 Rearm Never	Y
1 Rearm=1 (once)	
2 Rearm=2 (twice)	
3 Rearm=3 (three times)	
4 Rearm=Always	
41 Bell Delay (page 41)	41 ✓n✓
n = 0 No delay	Y
1 1.5 minutes	
2 3 minutes	
3 5 minutes	
4 10 minutes	
5 15 minutes	
6 20 minutes	
42 Bell Duration (page 41)	42 ✓n✓
n = 1 1.5 minutes	
2 3 minutes	
3 5 minutes	
4 10 minutes	
5 15 minutes	Y
6 20 minutes	

Command	Key in:
44 Level A Exit Time (page 41)	44 ✓n✓
n = 1 10 seconds	
2 20 seconds	Y
3 30 seconds	
4 45 seconds	
5 60 seconds	
6 120 seconds	
45 Entry/Exit Tone Volume (page 42)	45 ✓n✓
n = 0 No Entry/Exit tone from sounder	
n EE tone volume (1=low, 9=max)	5
46 Tamper Alarm Response (page 42)	46 ✓n✓
n = 0 Internal sounders only	
1 Keypad sounders only	
2 Internal and keypad sounders	Y
48 Lockout Keypads During Entry (page 42)	48 ✓n✓
n = 0 Off	Y
1 On	
49 Duress Code (page 42)	
n = 0 Disabled	Y
1 Enabled	
50 CSID Code (page 43)	50 ✓nnnn✓
nnnn = Central Station ID for remote reset	none
51 Set Time and Date (page 43)	51 ✓dd✓ mm✓yy✓ hh✓mm✓
dd Day of the month (01–31)	
mm Month of the year (01–12)	
yy Year (00–99)	
hh Hour of the day (01–23)	
mm Minute of the hour (01–59)	
52 Omit Alarm (page 43)	52 ✓n✓
n = 0 Alarm contacts only	Y
1 Alarm and tamper contacts	
53 Abort User/Engineer Reset (page 44)	53 ✓n✓
n = 0 Use option selected in Command 33	Y
1 User reset after an aborted alarm	
56 Number of Digits in Access Codes (page 44)	56 ✓n✓
n = 0 Four-digit codes	Y
1 Six-digit codes	
58 Day Tamper User/Engineer Reset (page 44)	58 ✓n✓
n = 0 User Reset	Y
1 Installer Reset	
59 External Sounder Tamper (page 44)	59 ✓n✓
n = 0 Negative voltage tamper return	Y
1 End of line 2k2 resistor	
60 Level B Final Exit Operation (page 45)	60 ✓n✓
n = 0 B=FE = FE (Final Exit)	Y
1 B=FE = NA (Normal Alarm)	
61 Level B Entry Route Operation (page 45)	61 ✓n✓
n = 0 B=ER = ER (Entry Route)	Y
1 B=ER = FE (Start entry timer)	

Command	Key in:
62 Level B Exit Mode (page 45)	62✓n✓
n = 0 Timed low tone on setting	Y
1 Instant (no exit tone)	
2 Silent (double "beep" after exit time)	
3 Sets exit mode the same as Level A	
63 Level B Alarm Response (page 45)	63✓n✓
n = 0 Keypad sounders only	
1 Internal and keypad sounders	Y
2 Local (all sounders, no comms)	
3 Full (all sounders and comms)	
65 Level B Exit Time (page 46)	65✓n✓
n = 1 10 seconds	
2 20 seconds	Y
3 30 seconds	
4 45 seconds	
5 60 seconds	
6 120 seconds	
67 Forbikobler Approved (page 46)	67✓n✓
n = 0 Frb=Non-Appr (not approved)	
1 Frb=Approved (approved)	Y
68 Forbikobler Door Timer (page 46)	68✓n✓
n = 0 2 seconds	
1 3 seconds	
2 4 seconds	
3 5 seconds	Y
4 10 seconds	
5 20 seconds	
6 30 seconds	
7 60 seconds	
8 120 seconds	
9 255 seconds	
69 Forbikobler Door Locking (page 46)	69✓n✓
n = 0 Lock Timed	Y
1 Lock Toggled	
70 Level C Final Exit Operation (page 47)	70✓n✓
n = 0 C=FE = FE (Final Exit)	Y
1 C=FE = NA (Normal Alarm)	
71 Level C Entry Route Operation (page 47)	71✓n✓
n = 0 C=ER = ER (Entry Route)	Y
1 C=ER = FE (Start entry timer)	
72 Level C Exit Mode (page 47)	72✓n✓
n = 0 Timed low tone on setting	Y
1 Instant (no exit tone)	
2 Silent (double "beep" after exit time)	
3 Sets exit mode the same as Level A	
73 Level C Alarm Response (page 47)	73✓n✓
n = 0 Keypad sounders only	
1 Internal and keypad sounders	Y
2 Local (all sounders, no comms)	
3 Full (all sounders and comms)	
75 Level C Exit Time (page 48)	75✓n✓
n = 1 10 seconds	
2 20 seconds	Y
3 30 seconds	
4 45 seconds	
5 60 seconds	
6 120 seconds	

Command	Key in:
76 Level D Exit Mode (page 48)	76✓n✓
n = 0 Timed low tone on setting	Y
1 Instant (no exit tone)	
2 Silent (double "beep" after exit time)	
3 Sets exit mode the same as Level A	
77 Level D Alarm Response (page 48)	77✓n✓
n = 0 Keypad sounders only	
1 Internal and keypad sounders	Y
2 Local (all sounders, no comms)	
3 Full (all sounders and comms)	
79 Level D Exit Time (page 48)	79✓n✓
n = 1 10 seconds	
2 20 seconds	Y
3 30 seconds	
4 45 seconds	
5 60 seconds	
6 120 seconds	
80 Forbikobler Chime (page 49)	80✓n✓
n = 0 Bell push does not operate sounders	Y
1 Bell push operates sounders	
81 Output 1 Type (page 49)	81✓nn✓
nn = Where n is one of:	
00 Bell	Y
01 EE Follow	
02 Armed Lamp	
03 Set Latch	
04 Shock Sensor Reset	
05 Walk Test	
06 Ready Lamp	
07 24-hour Alarm	
08 Strobe	
09 Smoke Sensor Reset	
10 French Siren Test	
11 Strobe Set	
12 Pulse Set 1	
13 Pulse Unset 1	
14 Confirmed	
15 Set Complete	
16 Unset Complete	
26 Pulse Set 1	
27 Pulse Set 2	
28 Pulse Set 3	
29 Pulse Set 4	
30 Pulse Unset 1	
31 Pulse Unset 2	
32 Pulse Unset 3	
33 Pulse Unset 4	
34 Fire	
35 PA	
36 Set Fail	
37 General Fault	
38 All Fault	

82	Output 2 Type (page 49)	82✓nn✓
nn =	See Command 81 for a list of options. Default is 08 Strobe	
83	Output 3 Type (page 49)	83✓nn✓
nn =	See Command 81 for a list of options. Default is 03 Set Latch	
85	Burg Communication Rearm (page 51)	85✓n✓
n =	0 Latched Y 1 Rearm	
87	Keypad Dual Key Alarms (page 52)	87✓n✓n✓n✓
n =	0 Off Y 1 On (PA enabled) 0 Off Y 1 On (Fire enabled) 0 Off Y 1 On (Medical enabled) Note: Setting PA to option 1 also enables a PA from keyswitches.	
88	Do not use.	
89	Alarm Confirmation (page 52)	89✓n✓
n =	0 None (default outside the UK) 1 UK (DD243) (default in the UK) 2 Two zones	
90	Event Log (page 52a)	90✓n✓
n =	Shows the most recent event in the log 1 View earlier events 3 View later events 4 First event 6 Last event ✗ Cancel viewing ✓ Toggles time/date display	
91	Test Normal Outputs 1 to 3 (page 52a)	91✓
	Keys 1 to 3 operate outputs 1 to 3, press ✗ or ✓ to end test	
92	Test Plug-by Outputs 1 to 8 (page 52a)	92✓
	Keys 1 to 8 operate outputs 1 to 8, press ✗ or ✓ to end test	
94	Test Internal Sounder (page 52a)	94✓
	Internal sounders operate, press ✗ or ✓ to end test	
95	Test Keypad Sounder (page 52a)	95✓
	Keypad sounders operate, press ✗ or ✓ to end test	
97	Engineer Walk Test (page 52a)	97✓
	Zn indication and Chime operate when circuit open ✗ End Walk Test	
98	Load Full Defaults (page 52a)	98✓1✓n✓
99	Leave Installer Mode (page 52a)	99✓✓

C101-158 are for programming communications.		
106	Line Fault Response (page 52a)	106✓n✓
n =	0 (not used) 1 Audible Y 2 Silent	
126	Select Language (page 53)	126✓n✓
nn =	0 = English Y 1 = Italian 2 = Espanol 3 = Port 4 = Nederl 5 = Francai 6 = Deutsch 7 = Norsk 8 = Svenska 9 = Dansk ✗1 = Suomi	
134	AC Fail User/Installer Reset (page 53)	134✓n✓
n =	0 No Reset Required Y 1 User Reset 2 Installer Reset	
135	Line Fault User/Installer Reset (page 54)	135✓n✓
n =	0 No Reset Required Y 1 User Reset 2 Installer Reset	
136	Anti-Mask User/Installer Reset (page 54)	136✓n✓
n =	0 User Reset Y 1 Installer Reset	
137	AC Fail Override (page 54)	137✓n✓
n =	0 Never 1 Inactive 2 Any Y	
138	Line Fault Override (page 54)	138✓n✓
n =	0 Never 1 If Only 1 Fault (not in 9651) 2 Any Y	
139	Fault User/Installer Reset (page 55)	139✓n✓
n =	0 User Reset Y 1 Installer Reset	
140	Fault Override (page 55)	140✓n✓
n =	0 Never Y 1 Inactive	
141	Alert Tone On/Off (page 56)	141✓n✓
n =	0 Off 1 On Y	

151	Plug-by Communications Output 1 (page 56)	151✓nn✓
nn =	00 Not Used	
	01 Fire	Y
	02 PA	
	03 Burglar	
	04 Open/Closed	
	05 Alarm Abort	
	06 Technical Alarm	
	07 Confirmed	
	11 AC Fail	
	12 Tamper Alarm	
	13 Open	
	14 Close	
	15 Zone Omitted	
	16 Medical	
	17 Keybox	
	18 Anti-Mask	
	19 Smoke Detector	
	20 Not used	
	21 Battery Fault	
	30 Pulse Set 1	
	31 Pulse Set 2	
	32 Pulse Set 3	
	33 Pulse Set 4	
	34 Pulse Unset 1	
	35 Pulse Unset 2	
	36 Pulse Unset 3	
	37 Pulse Unset 4	
	38 Set Fail	
	39 General Fault	
	40 All Fault	
152	Plug-by Communications Output 2 (page 56)	152✓nn✓
n =	See Command 151 for a list of options.	
	Default is 02 PA	Y
153	Plug-by Communications Output 3 (page 56)	153✓nn✓
n =	See Command 151 for a list of options.	
	Default is 03 Burglar	Y
154	Plug-by Communications Output 4 (page 56)	154✓nn✓
n =	See Command 151 for a list of options.	
	Default is 04 Open/Close	Y
155	Plug-by Communications Output 5 (page 56)	155✓nn✓
n =	See Command 151 for a list of options.	
	Default is 15 Zone Omitted	Y
156	Plug-by Communications Output 6 (page 56)	156✓nn✓
n =	See Command 151 for a list of options.	
	Default is 05 Alarm Abort	Y

157	Plug-by Communications Output 7 (page 56)	157✓nn✓
n =	See Command 151 for a list of options.	
	Default is 00 Confirmed	Y
158	Plug-by Communications Output 8 (page 56)	158✓nn✓
n =	See Command 151 for a list of options.	
	Default is 06 Technical	Y
159	Invert Plug-by Outputs (page 57a)	159✓nn✓
n =	0 Off (do not invert logic)	Y
	1 On (invert logic)	
C160 is valid only if C89 is set to option 1. C161-164 are valid if C89 is set to option 1 or 2.		
160	Confirmed Alarm Timer (page 57a)	160✓nnn✓
nnn =	a time from 001 to 999 minutes	030 minutes
161	Internal Sounder (page 57a)	161✓n✓
n =	0 Sounder on Unconfirmed Alarm	Y
	1 Sounder on Confirmed Alarm only	
162	External Sounder (page 57b)	162✓n✓
n =	0 Sounder on Unconfirmed Alarm	Y
	1 Sounder on Confirmed Alarm only	
163	Confirmed Alarm during Entry (page 57b)	163✓n✓
n =	0 Never (no zones)	Y
	1 One zone	
	2 Two zones	
164	User/Engineer Reset after Confirmed Alarm (page 57c)	164✓n✓
n =	0 User/Engineer	Y
	1 User/User	
	2 Engineer/Engineer	
170	Pulse Set 1 to 4 Duration (page 58)	170✓nn✓nn✓
nn =	00 to 12 seconds	01 seconds
171	Pulse Set Allocation (page 58)	171✓n✓n✓n✓
n =	A Level A	abcd
	B Level B	
	C Level C	
	D Level D	
172	Pulse Unset 1 to 4 Duration (page 58)	172✓nn✓nn✓nn✓
nn =	00 to 12 seconds	01 seconds
173	Pulse Unset Allocation (page 58)	173✓n✓n✓n✓
n =	A Level A	abcd
	B Level B	
	C Level C	
	D Level D	

174	Fire Pulse Unset (page58)	174✓n/n n/n/n/n	
n =	0 Off		
	1 On		Y
175	PA Pulse Unset 1 to 4 (page 58)	175✓n/n n/n/n/n	
n =	0 Off		
	1 On		Y
182	Set Final Exit Settling Time (page59)	182✓n/n	
n =	07 7 seconds		Y
	08 8 seconds		
	09 9 seconds		
	10 10 seconds		
	11 11 seconds		
	12 12 seconds		
183	Set Display Line 2 (page59)	183✓n..n/n	
n...n =	Maximum 16 digits (press C/D to move right/left)	<model_no>	
	Note: This is displayed in user mode. Its display in installer mode is toggled by Command 90.		
184	Pulsed External Sounder for Fire (page 59)	184✓n/n	
n =	0 Off		Y
	1 On		
185	Keyswitch Auto Reset (page 59)	185✓n/n	
n =	0 Off		Y
	1 On		
199	Display Zone Circuit Resistance (page 67)	199✓	
=	Use the A and C keys to step through circuits 1–8, or key in "1" to "8"		
200	Forbikobler Entry Timer (page60)	200✓n/n n/n/n/n	
n =	1 Entry Timer 1		Y
	2 Entry Timer 2		
	3 Entry Timer 3		
	4 Entry Timer 4		
201	Entry Timer 1 (page 60)	201✓n/n	
n =	1 10 seconds		
	2 20 seconds		Y
	3 30 seconds		
	4 45 seconds		
	5 60 seconds		
	6 120 seconds		
202	Entry Timer 2 (page 60)	202✓n/n	
n =	1 10 seconds		
	2 20 seconds		Y
	3 30 seconds		
	4 45 seconds		
	5 60 seconds		
	6 120 seconds		
203	Entry Timer 3 (page 60)	203✓n/n	
n =	1 10 seconds		
	2 20 seconds		Y
	3 30 seconds		
	4 45 seconds		
	5 60 seconds		
	6 120 seconds		
204	Entry Timer 4 (page 60)	204✓n/n	
n =	1 10 seconds		
	2 20 seconds		Y
	3 30 seconds		
	4 45 seconds		
	5 60 seconds		
	6 120 seconds		

Index

24-hour Alarm	50	load values for all commands	52a
Abort		restoring.....	28
Alarm	38	setting country defaults	30
reset after an Abort Alarm	44	Delay	
AC Fail Override	54	bell	41
AC Fail Reset.....	53	Dimensions of control unit case.....	7
Access code.....	4, 24, 27, 30	Display, setting text for second line	59
length.....	44	Door	
restoring	27	Forbikobler locking	46
Alarm		Forbikobler timer	46
Abort.....	38	Dual key alarm	52
dual key alarm.....	52	Duration	
entry alarm delay time	37	bell	41
Alarm response		Duress Code	2, 4, 27, 42
Level B	45	EN 50131 compliance.....	36, 37, 41, 54, 55, 60, 68
Level C	47	Engineer	
Level D	48	code	27, 35
Tamper Alarm response	42	performing engineer reset	28
Alert tone.....	56	walk testing	66
All Fault output.....	51	Entry alarm delay time	37
Anti-Mask		Entry Route response	
Mode	52a	Level B	45
Reset	54	Level C	47
Armed Lamp	49	Entry timer	
Auto rearm	40	1 to 4.....	60
Auxiliary output	8	Forbikobler.....	46, 60
Battery		Entry/Exit	
fitting.....	23	EE Follow output type	49
specification.....	7	tone.....	42
Bell	49	Environmental standard.....	7
delay.....	41	Exit fault external sounders	36
Duration.....	41	Exit mode	
tamper return.....	8	Level A.....	39
Bell-box connections.....	16	Level B.....	45
Burg communication rearm	51	Level C	47
Central Station Identification (CSID) Code.....	43	Level D	48
Chime		Exit Terminate button	
Forbikobler	49	connecting	15
loudspeaker.....	35	Exit time	
Clock		Level A.....	41
accuracy.....	7	Level B.....	46
setting.....	43	Level C	48
Closed Circuit Loop (CCL)		Level D	48
zone connection	18	External sounder	
Code		delay	41
access	4, 24, 27, 30, 44	on exit fault	36
CSID	43	pulsed output during Fire alarm	59
Duress	2, 4, 27, 42	tamper return.....	44
engineer	27, 35	Fault Override	56
Engineer	27	Fault Reset	55
Guard	35	Final Exit	
Communication output.....	8	Level B response.....	45
burg rearm	51	Level C response	47
Communicator.....	21	settling time	59
plug-by outputs.....	56	Fire alarm	
Control unit		programming outputs	51
cable entries to case	14	First circuit lockout	38
fitting the case	13	Forbikobler	
PCB layout	10	approved operation	46
power requirements	7	bell push operation	49
CSID.....	see Central Station Identification	definition	33
Date, setting.....	43	door locking	46
Daytime tamper reporting.....	39	door timer	46
Defaults		entry timer	60

Fully Supervised Loop (FSL)	35	output	8
connections	18	Mains connection	14
Fuses	8, 14	Modes of operation	25
General Fault output	51	Omit	
Guard Code	35	alarm contacts	43
Hide status display	36	omit zone attribute	31, 34
Humidity	7	tamper contacts	43
Input		Operating modes	25
line fault	8	Output	
remote reset	8	auxiliary	8
tamper	8	communication	8
Internal sounder		invert plug-by outputs	57a
delay	36	loudspeaker	8
duration	36	panel	8
Invert Plug-by Outputs	57a	plug-by communicator	56
Keypad	9	programming panel outputs	20, 49
addressing	16	testing	66
backlight	16	Override	
backplate	13	AC Fail	54
connecting	15	Fault	56
dual key alarm	52	Line Fault	55
lockout	42	PA	
power requirements	7	programming outputs	51
setting text for second line of display	59	reset	38
tamper switch	13	Panel output	8
Keyswitch		Part numbers of compatible equipment	9
automatic reset	59	PD6662 compliance	36, 37, 41, 54, 55, 60
fixed	32	Power	
momentary	32	connection	14
Kick start pins	24	requirements	7
Language selection	53	Programming	
Learning		entering installer mode	26
proximity tags	29	leaving installer mode	27
Level A		leaving programming mode	52a
exit mode	39	using programming commands	26
exit time	41	Proximity tag reader	
Level B		locking out keypads	42
alarm response	45	non-approved Forbikobler operation	46
Entry Route response	45	tag part number	9
exit mode	45	using proximity tags	28
exit time	46	Pulse	
Final Exit operation	45	programming output pulses	58
Level C		pulsed output to external sounder during Fire alarm	59
alarm response	47	Set 1	50
Entry Route response	47	Set 2	50
exit mode	47	Set 3	50
exit time	48	Set 4	51
Final Exit response	47	Unset 1	50, 51
Level D		Unset 2	51
alarm response	48	Unset 3	51
exit mode	48	Unset 4	51
exit time	48	Ready Lamp	50
Line		RedCare	see Remote reset
line fault input	8	Remote	
response to faults on line	52a	reset	36
Line Fault Override	55	setting device	42
Line Fault Reset	54	Reset	
Load		AC Fail	53
default values for all commands	52a	after abort	44
Lock switch		Anti-Mask	54
connecting	15	automatic resetting of keyswitch zones	59
Lockout		Fault	55
first circuit	38	Line Fault	54
keypads	42	PA alarm	38
Log		performing engineer reset	28
viewing event log during testing	63	remote	36
Loudspeaker		shock	50
Chime	35		

system reset.....	38	external sounder connection.....	44
Restore		reporting tampers while unset.....	39
access codes	27	return for Bell.....	8
defaults.....	28	system tamper reset.....	39
Set Complete	50	tamper indication	44
Set Fail output.....	51	zone tamper reset	38
Set Latch.....	50	Tellback.....	see Remote reset
Settling time for Final Exit.....	59	Temperature.....	7
Shock reset.....	50	Test	
Show status display.....	36	outputs.....	66
Silent or audible PA	37	walk testing.....	66
Siren Test.....	50	Time	
Size of control unit case	7	accuracy.....	7
Smoke reset.....	50	setting.....	43
Sounder connections.....	16	Unset Complete	50
Start up	24	Walk Test	50, 66
Status display.....	36	Weight	7
Strobe		Zone	
Strobe output type.....	50	CCL	18
Strobe Set A output type.....	50	FSL	18
System		naming zones	30
automatic rearm	40	programming	30
reset.....	38	setting wiring type.....	35
tamper reset.....	39	setting zone attributes	33
Tamper		setting zone type	31
alarm response	42	tamper reset	38
day tamper reset.....	44	wiring	18

NOTES:

9651

NOTES:

Eaton
Security House
Vantage Point Business Village
Mitcheldean
Gloucestershire
GL17 0SZ
www.touchpoint-online.com

Product Support (UK) Tel: +44 (0)1594 541978
Available between: 08:30 and 17:00 Monday to Friday.
Email: securitytechsupport@eaton.com

Part Number 12593879
Declarations of conformance to standards can be obtained from our Web site, www.touchpoint-online.com